



Kiwi Car Insurance

Policy Wordings

Product UIN

IRDAN171RPMT0001V01202627



Product UIN

IRDAN171RPMT0001V01202627

This is a contract between you and Kiwi General Insurance Limited.

We will insure your vehicle based on the information and declarations made by you, the premium paid by you and the terms and conditions of this Policy shown in the Policy Schedule and Endorsement if any. This Policy provides cover only within India, unless specified otherwise in your Policy Schedule. The Policy wording, the Policy Schedule, the Certificate of Insurance and any Endorsement form a single contract and must be read together. Any word or expression once defined in any of these documents means the same wherever it is used in this Policy. We will provide the covers (including any optional covers you have chosen) up to the limits stated in your Policy Schedule or Endorsement.

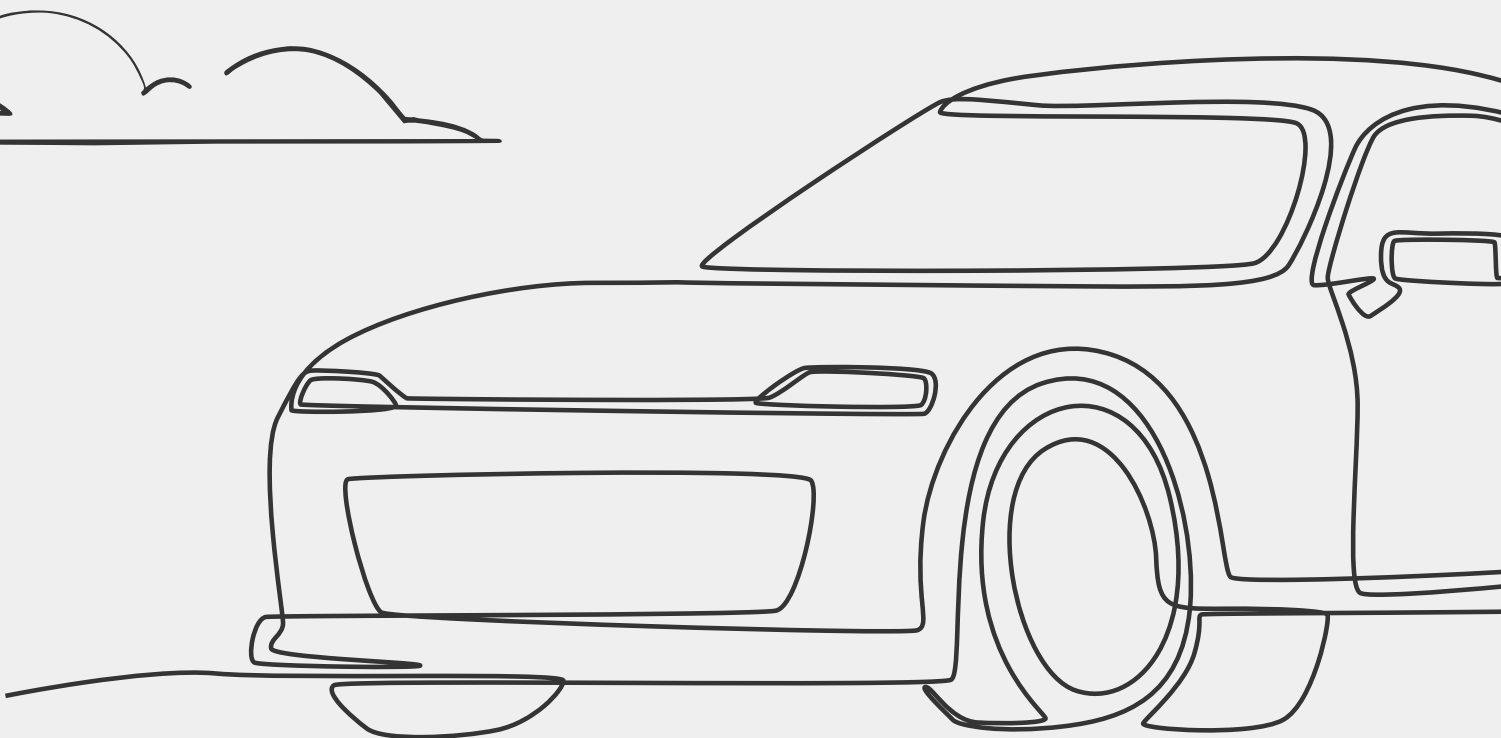

We will encourage you to read all your policy documents carefully.

A. Definitions

Words used in the policy are defined in this section. Any word defined means the exact same thing throughout all your policy documents, whether it's singular or plural, regardless of gender, and including any updated laws.

1. **Car** is a vehicle which is insured by us in this policy and is registered in your name with the Regional Transport Authority in India. The word car and vehicle can be used interchangeably.
2. **Constructive Total Loss (CTL)** means the condition of the vehicle where the aggregate cost of retrieval and/or repair of the vehicle, subject to terms and conditions of the policy, exceeds 75% of the Sum Insured.
3. **Deductible** means the amount which you have to bear first in respect of each and every claim under the Policy. We will pay the amount which is over and above the Deductible mentioned in the Policy/Policy Schedule.
4. **Endorsement** means an authorised variation and/or amendment and/or addition to your Policy by us and forms part of the Policy.
5. **OEM Network** means OEM authorised garage/workshop/service station
6. **Family member** means your Spouse, Parents, Parents-in law, Grand Parents, Children, and Sibling.
7. **Garage Network** means garages empanelled by the Insurer and/or consolidated organisations to provide motor related services. The Garage Network is divided into 3 categories:
 - **Cashless Garage Network:** Only Cashless facility available.
 - **Kiwi Preferred Garage (KPG) Network:** Cashless facility available with preferred terms.
 - **Kiwi Preferred Garage+ (KPG+) Network:** Cashless facility with preferred terms and value-added services.
 - **Visit for the updated garage network:** <https://www.kiwiinsurance.com/cashless-garages/>



8. **Home contents** means the everyday household goods and personal belongings owned/ hired by you and the family members who live with you, provided these items are kept inside the property listed in your policy.
9. **Hospitalisation** means admission in a Hospital for a minimum period of 24 consecutive 'In-patient Care' hours except for specified procedures/treatments, where such admission could be for a period of less than 24 consecutive hours.
10. **IMT** means the erstwhile India Motor Tariff, 2002. The IMT numbers referenced in this policy wording correspond to standard endorsements and provisions under the said tariff.
11. **Insured event** means an accident or an event during the Policy Period, caused by or arising out of perils covered under the Policy / Endorsements / Optional Covers during the use of the vehicle within the geographical area mentioned in the Policy Schedule. The word Insured event and accident can be used interchangeably.
12. **Injury** means accidental physical bodily harm excluding illness or disease solely and directly caused by external, violent, visible and evident means which is verified and certified by a Medical Practitioner.
13. **Key** means any device provided by the manufacturer when the vehicle was new, to start or unlock the vehicle. This includes: Standard mechanical metal keys, Smart keys / Proximity keys (Keyless entry), Remote key fob, Remote locking devices.
14. **Medical Practitioner** means a person who holds a valid registration from the Medical Council of any State or Medical Council of India or Central Council of Indian Medicine or Central Council of Homeopathy set up by the Government of India or a State Government and is thereby entitled to practice medicine within its jurisdiction and is acting within its scope and jurisdiction of license.
15. **Medically Necessary Treatment** means any treatment, tests, medication, or stay in Hospital or part of a stay in Hospital which:
- is required for the medical management of the Injury suffered by You/ Driver/ Occupants;
 - must not exceed the level of care necessary to provide safe, adequate and appropriate medical care in scope, duration, or intensity;
 - must have been prescribed by a Medical Practitioner;
 - must conform to the professional standards widely accepted in international medical practice or by the medical community in India.

16. **Nominee** means the person or persons named by the owner-driver and specified in the Policy Schedule as Nominee to receive the benefits payable under this Policy in the event of the death of the Owner-driver. If the Nominee is below 18 years of age, an adult appointee/guardian shall be appointed to receive the benefits on behalf of the minor until the minor attains majority.
17. **Outpatient Department (OPD) treatment** means the one in which the insured visits a clinic / Hospital or associated facility like a consultation room for diagnosis and treatment based on the advice of a Medical Practitioner. The insured is not admitted as a day-care or in-patient.
18. **Panel** means the external body part of the vehicle which forms the outer shell of a vehicle like Bumpers, Fenders, Hood, Doors, Roof & Deck lid/Tailgate, pillars, rocker panels.
19. **Personal belongings** means items of personal nature which can be worn, used or carried. Example: clothes, luggage, mobile phones, laptops, tablets, electronic accessories. Personal documents like driving licence, registration certificate and items of similar nature.
20. **Policy** means the Proposal, the Policy Schedule, the Certificate of insurance, the policy wordings (this document) and any endorsement We have issued under this Policy, all of which should be read together as one contract.
21. **Policy period** means the period mentioned in the Policy Schedule during which the policy is valid and operative.
22. **Policy Schedule** means schedule attached to the policy.
23. **Policy Year** means a period of twelve consecutive months commencing from the Policy commencement date or from any subsequent Policy anniversary during the Policy period. In case of long-term Policy, exceeding twelve months, each successive twelve-month period shall be treated as a separate Policy year, except that the final Policy year may be of a shorter duration if the Policy period does not end on a Policy anniversary. In case of short-term Policy, less than twelve months, the policy period will be equal to as mentioned in the Policy Schedule.
24. **Proposal** means, the application or questionnaire form, (including any declarations, statements and disclosures made thereunder) completed and made by or for You, whether in writing, online, over the phone or otherwise via secured medium.
25. **Reasonable and Customary charges** means the charges for services or supplies, which are the standard charges for the specific provider and consistent with the prevailing charges in the geographical area for identical or similar services, taking into account the nature of the Illness / Injury involved.

Product UIN

IRDAN171RPMT0001V01202627

26. **Salvage** is the damaged property or asset for which claim has been paid under the policy.
27. **You, Your, Yourself** means the person/organisation named in the Policy Schedule as insured and under whose name this Policy is issued. In case Policy Schedule refers to an organisation, then the representative / employee to whom vehicle has been allotted for his/her use, would be deemed as You, Your, Yourself.
28. **We, Us, Our, Ourselves** means Kiwi General Insurance Limited.

B. Coverage

Section 1: Loss or Damage to the Vehicle (Own Damage)

1. We will pay for the physical loss or damage to your vehicle and its installed accessories, in case of:
 - a. Fire, explosion, self ignition or lightning
 - b. Burglary, housebreaking or theft
 - c. Riot and strike
 - d. Earthquake (fire and shock damage)
 - e. Flood, typhoon, hurricane, storm, tempest, inundation, cyclone, hailstorm, frost
 - f. Accidental external means
 - g. Malicious act
 - h. Terrorist activity
 - i. Whilst in transit by road, rail, inland-waterway, lift, elevator or air
 - j. Landslide / rockslide

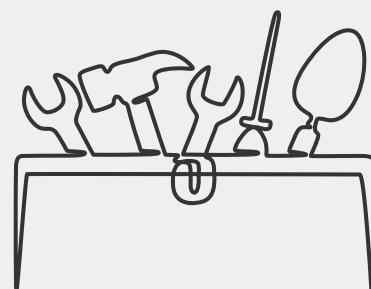

2. Below Depreciation rates will be applied for replacement of parts/accessories:

- a. All rubber/ nylon / plastic parts/ tyres and tubes/ batteries/ air bags - 50%
- b. Fibre glass components - 30%
- c. All parts made of glass - Nil
- d. All other parts including wooden parts as per the following schedule.

Age of Vehicle	% of Depreciation
Not exceeding 6 months	Nil
Exceeding 6 months but not exceeding 1 year	5%
Exceeding 1 year but not exceeding 2 years	10%
Exceeding 2 years but not exceeding 3 years	15%
Exceeding 3 years but not exceeding 4 years	25%
Exceeding 4 years but not exceeding 5 years	35%
Exceeding 5 year but not exceeding 10 years	40%
Exceeding 10 years	50%

- e. **Rate of depreciation for painting:** 50% depreciation rate will be applied on the total material cost. We will consider painting material cost as 25% of the total bill in case of a consolidated bill.
- f. In case of repair, no depreciation shall be deducted on Non-OEM (Original Equipment Manufacturer) / Non-OES (Original Equipment Supplier) parts that are used in repairs.

3. Towing

We will pay for towing your car to and fro from the nearest garage/workshop/service station, if your car was damaged or disabled in any one Insured event as per your policy.

4. We will not pay for

- a. Consequential loss, depreciation, wear and tear, mechanical or electrical breakdown, failures or breakages.
- b. Damage to tyres and tubes unless the car is damaged at the same time in which case maximum 50% of the cost of replacement will be paid by us.
- c. Loss or damage, If the driver (you or anyone driving with your consent) was under the influence of alcohol or drugs at the time of the Insured event.

5. Sum Insured- Insured's Declared Value (IDV)

The Insured's Declared Value (IDV) will be the sum insured for your policy and will be fixed at the start of the policy year/ period for your car. The IDV is derived and fixed on the basis of the manufacturer's listed selling price for your car (and non-electrical accessories if any fitted to the vehicle) and is adjusted for depreciation at the start of the policy and at renewal.

Depreciation Schedule: Fixing DIV

Age of Vehicle	% of Depreciation (for fixing IDV)
Not exceeding 6 months	5%
Exceeding 6 months but not exceeding 1 year	15%
Exceeding 1 year but not exceeding 2 years	20%
Exceeding 2 years but not exceeding 3 years	30%
Exceeding 3 years but not exceeding 4 years	40%
Exceeding 4 years but not exceeding 5 years	50%

Product UIN

IRDAN171RPMT0001V01202627

- IDV of vehicles beyond 5 years of age or obsolete models of the vehicles (i.e. models which the manufacturers have discontinued to manufacture) or Vintage / Classic cars, or where you require a deviation from the above schedule, is to be determined based on an understanding between You and Us.
- IDV shall be treated as the “Market Value” throughout the policy year/ period without any further depreciation for the purpose of claims of Total Loss (TL) / Constructive Total Loss (CTL) and theft of vehicle.
- If the total cost to retrieve or repair the car is more than 75%, the car will be treated as CTL.

Section 2: Liability to third parties

1. We will indemnify You subject to the limits of liability as mentioned in the Policy Schedule, in the event of an accident during the Policy period, caused by or arising out of the use of the vehicle, against all sums which You will become legally liable to pay in respect of: -
 - a. Death of or bodily injury to any person including occupants carried in the insured vehicle (provided such occupants are not carried for hire or reward) but except so far as it is necessary to meet the requirements of Motor Vehicles Act, We shall not be liable where such death or injury arises out of and in the course of the employment of such person under You.
 - b. Damage to property other than property belonging to You or held in trust or in Your custody or control.
2. We will pay all costs and expenses incurred with regard to Section 2: 1.a and Section 2: 1.b above with Our written consent.
3. Indemnification as above shall also extend to any driver who is driving the vehicle on Your order or with Your permission provided that such driver shall as though he/ she was the insured, observe fulfil and be subject to the terms, exceptions and conditions of this Policy in so far as they apply, subject to the limitations of the indemnity granted by this section to You.

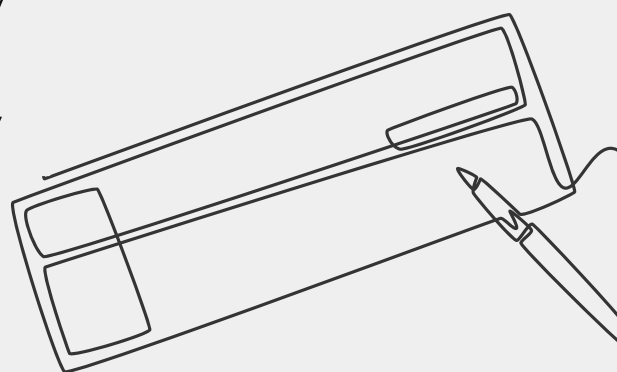

4. In the event of the death of any person entitled to indemnity under this policy, We will indemnify his/her personal representative, in respect of the liability incurred by such person, subject to terms and limitations of this Policy, provided that such personal representative, shall as though was the insured, observe, fulfil and be subject to the terms, exceptions and conditions of this Policy in so far as they apply.

5. We may at Our discretion:
 - a. Arrange for representation at any Inquest or Fatal Inquiry, in respect of any death which may be the subject of indemnity under this Policy and
 - b. Undertake the defence of proceedings in any Court of Law, in respect of any act or alleged offence, causing or relating to any event, which may be the subject of indemnity under this Policy.

6. Application of limits of indemnity:
 - a. In the event of any accident involving indemnity to more than one person, any limitation by the terms of this Policy and/or any Endorsement on the amount of any indemnity, shall apply to the aggregate amount of indemnity to all persons indemnified, and such indemnity shall apply in priority to You.
 - b. Legal Liability to employees of the insured other than paid driver and /or conductor and/or cleaner who may be travelling or driving in the Employer's vehicle:
 - We will indemnify You subject to the terms, exceptions, conditions and limitations of this Policy, against Your liability at Common Law and Statutory Liability under the Fatal Accidents Act, 1855 for compensation (including legal costs of any claimant) for death of or bodily injury to Your employee (other than paid drivers) being carried in or upon or entering in or getting on to or alighting from or driving the insured vehicle.
 - Provided that in the event of an accident, whilst the insured vehicle is carrying more number of employees (including the driver) than the seating capacity of the insured vehicle as per Registration certificate, then You shall repay Us a rateable proportion of the total amount payable by Us in respect of accident in connection with such insured vehicle.

Section 3: Personal Accident Cover for Owner-Driver

We will pay compensation as per the following scale, expressed as the percentage of sum insured mentioned in the Policy Schedule against this cover for bodily injury/ death sustained by You, being the Owner-driver of the vehicle, in direct connection with the insured vehicle or whilst driving or mounting into or dismounting from the insured vehicle or whilst travelling in it as a co-driver, caused by violent, accidental, external and visible means which independent of any other cause shall within six calendar months of such injury result in:

Nature of injury	Scale of compensation
(i) Death	100%
(ii) Loss of two limbs or sight of two eyes or one limb and sight of one eye.	100%
(iii) Loss of one limb or sight of one eye	50%
(iv) Permanent total disablement from injuries other than named above	100%

Provided always that:

1. Compensation shall be payable to You under only one of the items (i) to (iv) above, arising out of any one occurrence and Our total liability shall not in the aggregate exceed the sum insured mentioned in the Policy Schedule during any one Policy year.
2. No compensation shall be payable in respect of death or bodily injury directly or indirectly, wholly or in part, arising or resulting from or traceable to
 - a. intentional self injury, suicide or attempted suicide, physical defect or infirmity or
 - b. An accident happening, whilst you or any person is driving under the influence of alcohol or drugs or other intoxicant.
3. Such compensation shall be payable directly to You or to Your Nominee, legal heirs or representatives whose receipt shall be the full discharge in respect of the injury or death to You.

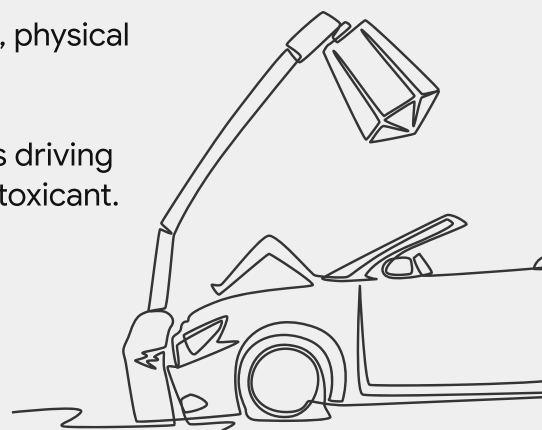

Product UIN

IRDAN171RPMT0001V01202627

This cover is subject to:

- a. You being the registered owner of the insured vehicle;
- b. You being the insured named in this Policy;
- c. You hold an effective driving licence, in accordance with the provisions of Rule 3 of the Central Motor Vehicles Rules, 1989, at the time of the accident.

C. Optional Covers

All of the covers in this section shall be in consideration of the payment of an additional premium (unless mentioned as a discount within the relevant coverage definition) and shall be subject to the terms, conditions, exclusions and limitations of this policy.

1. Zero Depreciation Cover

We will pay:

1. For the amount of depreciation deducted on the admissible value of replaced parts and paint materials under a claim in this policy under “Section 1: Own Damage”.
2. For the applicable number of claims specified in your Policy Schedule.

Cover Conditions: Applicable only if there is an admissible claim under “Section 1: Own Damage” in this policy.

We will not pay if the vehicle is not repaired at our Garage Network or OEM Network.

2. Return to Invoice

In the event of Total Loss(TL) /Constructive Total Loss(CTL) / Theft of the insured vehicle during the Policy period,

We will pay:

1. The difference between IDV of the insured vehicle and the invoice price (as published by the manufacturer) of the new vehicle (similar make, model, variant, features, specifications)

Product UIN

IRDAN171RPMT0001V01202627

2. One year insurance premium (including any optional benefits) by multiplying Insured's Declared Value (IDV) of the new vehicle of same or similar make, model and variant considered above with Own Damage premium rate of Your existing vehicle's policy & applicable Basic Third Party Premium.
3. The garage estimation charges and **parking charges up to 2% of IDV or actual**, whichever is less, subject to submission of bill.

Cover Conditions:

1. The Invoice price of the Insured Vehicle also includes the expenses incurred towards the payment of any applicable road tax and registration charges incurred less subsidy (if availed) with respect to such new vehicle.
2. In case of Imported vehicles directly from the manufacturer abroad the Invoice price will mean the landed cost of a new vehicle of the same or similar make, model and variant
3. In case the same make/mode/variant is unavailable or obsolete, then the last available invoice price of the same make/model/variant will be considered.
4. We will pay the difference as applicable on the Date of Accident.
5. In case You are a subsequent owner of the vehicle, We will pay the difference between the Insured Declared Value (IDV) of the insured Vehicle and the purchase price of the vehicle at the time of purchase by You.

We will not pay:

1. If we have not paid for a claim in this policy under "Section 1: Own Damage".
2. If the IDV is greater than the invoice value.
3. If the Final investigation report of the police, confirming the theft of the vehicle, is not submitted to Us.
4. For items not listed in Section 1 of the policy, even if they are part of the invoice. Items like non-built in electrical/electronic and non-electrical/electronic accessories including bi-fuel kit.

3. Consumables Cover

We will pay, for the cost of consumables (engine oil, gear box oil, lubricants, nut & bolt, screw, distilled water, grease, oil filter, bearings, washers, clips, break oil, air conditioner gas and items of similar nature excluding fuel) required to be replaced or replenished.

Cover Conditions: Applicable only if there is an admissible claim under “Section 1: Own Damage” in this policy.

We will not pay if the vehicle is not repaired at our Garage Network or OEM Network.

4. Preferred Garage Cash

We will pay, an additional fixed amount (as shown in your Policy Schedule) in case of a claim.

Cover Conditions:

1. Applicable only if there is an admissible claim under “Section 1: Own Damage” in this policy.
2. You must notify us first, before taking the vehicle to the garage in case of an accident.
3. You must choose to get your vehicle repaired only at one of our officially approved Kiwi Preferred Garage (KPG) Network and Kiwi Preferred Garage+ (KPG+) Network.

We will not pay:

1. If the claim is to repair or replace the windshield/glass only.
2. If the claim was notified to Us from someone other than You or Your family.

5. Repair Safeguard

If you choose to **repair rather than replace** the damages to Glass/Plastic/Rubber/Fibre Parts, Alloy Wheels and Wiring Harness, in case of a claim under “Section 1: Own Damage” then:

1. Your NCB/Super NCB will not be impacted at the time of Renewal with us.
2. Depreciation on paint material will not be deducted under this benefit.

Cover Conditions:

1. Applicable only if there is an admissible claim under “Section 1: Own Damage” in this policy.
2. Applicable only if the vehicle is repaired at our Garage Network or OEM Network

We will not pay if there is no repair, except painting, to the associated parts.

6. Owner Driver Accident Cover Booster

Enhances Your limits for payout under the benefit “Section 3 Personal Accident Cover for Owner-Driver”.

We will pay, if you are the owner driver and in case of injury or death while driving, travelling, entering, or exiting the insured vehicle, we will pay out according to the scale below, expressed as the percentage of sum insured mentioned in the Policy Schedule against this cover.

The injury or death must be from a clear, physical accident caused by external violent and visible means which (unrelated to any other medical cause) results in one of the following within six calendar months from the event of injury.

Nature of injury	Scale of compensation
(i) Death	100%
(ii) Loss of two limbs or sight of two eyes or one limb and sight of one eye.	100%
(iii) Loss of one limb or sight of one eye	50%
(iv) Permanent total disablement from injuries other than named above	100%

Cover Conditions:

1. For a single accident, we will only pay for one injury category (items i to iv). This payment is in addition to the coverage under Section 3 of this policy. However, the total payout during the policy year will never exceed the maximum limit shown in your Policy Schedule.

Product UIN

IRDAN171RPMT0001V01202627

2. You are the registered owner of the vehicle.
3. You are the Insured named in the policy.
4. You hold a valid driving licence (as required by the Central Motor Vehicles Rules, 1989) at the exact time of the accident.
5. We will pay this compensation directly to you, your nominee, your legal heir or your legal representatives. Once you (or they) accept this payment, the claim for your injury or death is considered fully settled and closed.

We will not pay for any compensation for any death or injury caused (directly or indirectly) by:

- i. Intentional self-harm, suicide, attempted suicide, or any existing physical defects or conditions; or
- ii. An accident that happens while the person is under the influence of alcohol, drugs, or other intoxicants. (Exception: If you are intoxicated but someone else is driving the vehicle, this exclusion does not apply to you).

7. Passenger Accident Cover Booster

We will pay, if you are an unnamed person(s)/passenger(s) in direct connection with the insured vehicle and in case of injury or death while driving, travelling, entering, or exiting the insured vehicle, we will pay out according to the scale below, expressed as the percentage of sum insured mentioned in the Policy Schedule against this cover.

The injury or death must be from a clear, physical accident caused by external violent and visible means which (unrelated to any other medical cause) results in one of the following within six calendar months from the event of injury.

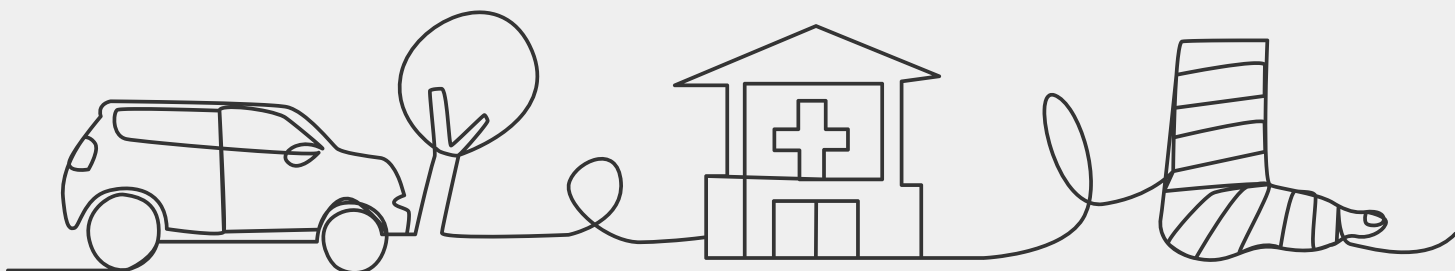

Nature of injury	Scale of compensation
(i) Death	100%
(ii) Loss of two limbs or sight of two eyes or one limb and sight of one eye.	100%
(iii) Loss of one limb or sight of one eye	50%
(iv) Permanent total disablement from injuries other than named above	100%

Cover Conditions:

1. For a single accident, we will only pay for one injury category (items i to iv) per person. This payment is in addition to the coverage under 'IMT 16: Personal Accident to Unnamed Passengers'. However, the total payout for any one person during the policy year will never exceed the maximum limit shown in your Policy Schedule. The number of people covered will also be the same as declared in IMT 16.
2. If the injured person was driving the insured vehicle, he must have held a valid driving licence (as per Rule 3 of the Central Motor Vehicles Rules, 1989) at the exact time of the accident.
3. We will only pay this compensation with your approval. Payments will be made directly to the injured person or their legal heirs. Once you (or they) accept this payment, the claim for your injury or death is considered fully settled and closed.

We will not pay for any compensation for any death or injury caused (directly or indirectly) by:

- i. Intentional self-harm, suicide, attempted suicide, or any existing physical defects or conditions; or
- ii. An accident that happens while the person is under the influence of alcohol, drugs, or other intoxicants. (Exception: If you are intoxicated but someone else is driving the vehicle, this exclusion does not apply to you).

8. Towing Booster

Enhances Your limits for “Towing” under the benefit “Section 1: Own Damage”.

Product UIN

IRDAN171RPMT0001V01202627

We will pay, for the additional charges (over and above the base Towing limit under “Section 1: Own Damage” as specified in this Policy Schedule) for the cost of towing your vehicle to the nearest Garage/Workshop/Service Station.

Cover Conditions: Applicable only if there is an admissible claim under “Section 1: Own Damage” in this policy.

We will not pay

1. For any consequential loss or damage.
2. If the loss is covered under the Manufacturer's warranty or recall campaign.

9. Flexi Repair

We will pay, to repair minor scratches, dents or chipped paint on your vehicle's panels that happen during the policy period, even if you choose not to fix them right away.

Cover Conditions:

1. This benefit is activated on the basis of a mandatory inspection of the vehicle — conducted either by us before policy issuance, or by you after policy issuance.
2. You can get the damage repaired along with a valid claim under “Section 1: Own Damage” of this policy, as long as you remain insured with us and continuously renew your policy without any breaks.
3. Applicable only if the vehicle is repaired at our Garage Network or OEM Network.
4. We will pay up to the limit mentioned in your Policy Schedule.
5. If the cumulative admissible expenses along with this benefit payout turns out to be more than 75% of the sum insured, it will be treated as a CTL.

We will not pay, for any pre-existing damages as noted in the pre-inspection report before activating this cover.

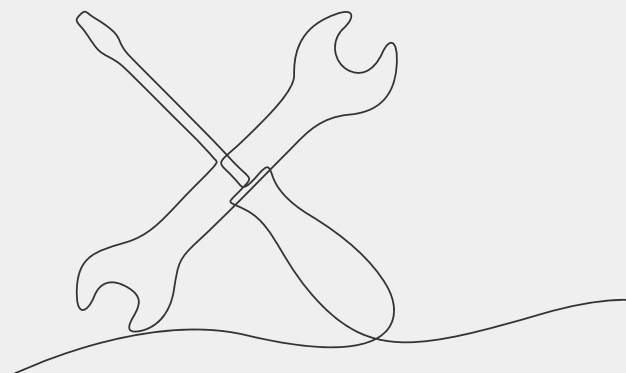

10. Super No Claim Bonus (Super NCB)

1. Gives You a discount on premium under “Section 1: Own Damage”, including discounts and loadings as per erstwhile IMT.
2. We will replicate your past claims experience (as available with Us) as per the Super NCB discount scale and working of Super NCB.
3. Working of Super NCB:
 - i. Works on a discount scale, where You can move one level up (higher discount) or down (lower discount) basis claim made or pending during the preceding policy year.
 - ii. You move up in case of no claim and move down in case of claim made.
 - iii. You will move ONLY one level down on the scale even if you claim multiple times in the particular policy year.

Super NCB Discount Scale:

Level	Super NCB Discount %
Level 7	90%
Level 6	80%
Level 5	70%
Level 4	60%
Level 3	40%
Level 2	30%
Level 1	0%

Conditions:

1. If eligible & opted, the No Claim Bonus will be replaced with Super No Claim Bonus.
2. Accumulation and Transfer of Super NCB is applicable if the vehicle was continuously insured for at least 12 months and the policy renewed within 90 days of expiry date.
3. Transfer of No Claim Bonus
 - i. Super NCB belongs to the original insured and not linked to the vehicle or policy. Which means for transfer of policy, the Super NCB will depend upon the new owner's eligibility except in the below cases:
 - a. Legal heirs (spouse, children, parents) take custody of the vehicle upon the insured's death.
 - b. Employees take custody of the institution-owned vehicle used exclusively by them, subject to employer confirmation for exclusive operation during the period in which the Super NCB was earned.
4. Super NCB will not be affected at renewal of this policy in case:
 - a. Claim under optional benefits where condition of claim admissibility under "Section 1: Own Damage" of the Policy is not required.
 - b. Damage to only windshield glass of the insured vehicle by external objects.
 - c. Loss due to flood/earthquake/act of god perils to the insured parked vehicle.
5. If your policy is eligible for a Super NCB discount, then the NCB discount (Section F.12) of the policy will not apply. Either Super NCB or NCB discount will apply as per eligibility.

11. Personal Belongings Cover

We cover the loss and damage to your personal belongings which were present in the vehicle at the time of an accident.

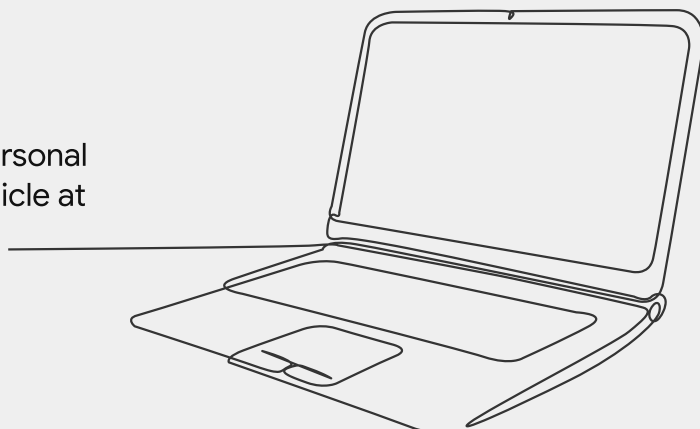

Product UIN

IRDAN171RPMT0001V01202627

We will pay:

1. The cost for repair of the items, and where repair is not possible, we will pay for or just replace the same or with an item of similar specifications and quality
2. We will only pay for the cost of getting a duplicate document in case of loss of any personal document, driving licence and/or registration certificate.

Cover Conditions: Applicable only if there is an admissible claim under “Section 1: Own Damage” in this policy.

We will not pay:

1. If you fail to provide a Police First Information Report (FIR) in case of theft or burglary.
2. We will not pay if the items lost are:
 - Money, cheques, and bank drafts.
 - Credit or debit cards.
 - Jewellery, watches, and glasses/lenses.
 - Travel tickets.
 - Paintings or manuscripts.
 - Business Goods: Any samples or goods you are carrying for trade or business purposes.

12. Engine Secure

We will secure Your insured vehicle’s engine from the loss or damage as per below mentioned cases:

We will pay for the cost of repair or replacement for loss or damage to:

- a. Internal Engine Parts
- b. Gear Box, Transmission or Differential Assembly
- c. Oil and lubricants (engine oil, gear oil etc) used in the engine/respective assembly

Cover Conditions

1. Applicable only if the damage to the engine/respective assembly is caused by:
 - a. Water ingress in the engine due to waterlogging. In such a case, You must have the vehicle towed to a garage within 2 days of the water receding.
 - b. leakage of lubricating oil from oil sump/engine assembly in an accident to the vehicle.
2. You must act responsibly after an accident, and avoid doing anything that could make the damage worse.

We will not pay:

1. If you are unable to share with us the evidence that the car was submerged/ stopped in water and or of accidental damage to showcase the leakage of lubricating oil.
2. If the damage is covered by the manufacturer's warranty or recall or preventive maintenance.
3. For depreciation, if the Zero Depreciation cover is not opted.
4. Any aggravation caused by rust or corrosion because you waited too long to tell us or remove the vehicle from the water-logged area.
5. Any issues related to the Diesel Particulate Filter (DPF) caused by driving habits, clogging, or soot or any cause not related to the accident.

13. Tyre Secure

We will secure Your vehicle's tyres from the loss or damage as per below mentioned cases:

We will pay to replace the damage or loss of tyres and tubes, in an accident.

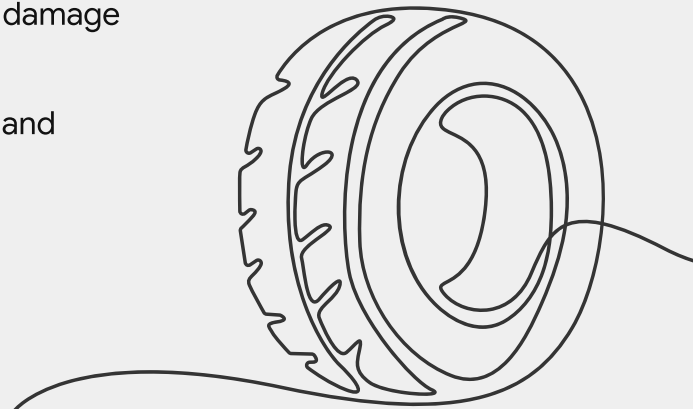

Cover Conditions

1. We will replace the tyre with the same brand and specification as the old one. And If the exact tyre is unavailable, and the replaced tyre is a better or superior tyre (an upgrade), then we will not pay the extra cost. We will pay the standard tyre cost and the difference will be paid by You.
2. In case the damage to the tyre is because of an accident covered in “Section 1: Own Damage” then we will pay the difference of depreciation percentage applied under “Section 1: Own Damage” and the cost of repair or replacement of the tyre.
3. We will allow a maximum of 4 replacements in the policy period.
4. All claims must be reported within 3 days of loss or damage.
5. You must treat the tyre with care and not continue to use the vehicle even if there is damage which may lead to further deterioration.
6. Claim under this benefit **will not impact** the No Claim Bonus/ Super No Claim Bonus.

We will not pay for:

1. Loss or damage due to natural wear and tear. If the unused tread depth is less than 3mm, we will consider it as natural wear and tear.
2. If the tyres are worn out unevenly because the car was not maintained properly. Like steering alignment not within the manufacturer’s limits, wheel imbalance, damage caused by faulty suspension, wheel bearings, or shock absorbers.
3. Loss or damage within the first 15 days of the start of this cover.
4. Loss or damage occurred prior to inception of the policy.
5. Loss or damage resulting in Total loss/Constructive Total Loss of the vehicle.
6. Loss or damage to wheel accessories, any other parts or rim.
7. Theft of tyre, tube or other accessories of the vehicle or the entire vehicle.
8. If the tyre(s)/tube(s) being claimed is different from tyre(s) insured/supplied as original equipment along with the vehicle unless informed to us and endorsed on the policy.
9. Fraudulent acts committed by insured or the workshop or any person entrusted possession of the vehicle by insured.
10. Loss or damage arising out of improper storage or transportation.

11. Consequential loss or damage which does not affect the tyre function or performance.
12. Loss or damage arising out of modifications not approved by the tyre manufacturer.
13. Loss or damage resulting from hard driving due to race, rally or illegal activities.
14. Loss or damage due to neglect of periodic maintenance as specified by the manufacturer.
15. Loss or damage resulting from poor workmanship while repairing.
16. Loss or damage arising out of any manufacturing defect or design including manufacturer's recall.
17. Minor damage or scratch not affecting the functioning.

14. Rim Secure

We will pay to repair or replace your vehicle's rim(s) if they are physically damaged, bent, or warped while driving during the policy year/ period. If we replace the rim, we will also cover the costs for wheel balancing, balancing weights, and wheel alignment.

Cover Conditions

1. If a rim(s) needs replacement, we will provide one of the exact same make and specifications. If an exact match is no longer available, we will pay for a similar rim(s) (which cannot be an upgrade from the original) or the last known invoice price of the original, whichever is lower.
2. Making a claim under this specific cover **will not impact** your No Claim Bonus (NCB)/Super NCB.
3. You must take reasonable steps to prevent damage to your rims. You must stop driving immediately after an incident if continuing to drive would cause further damage to the rim.
4. We will cover a maximum of 4 rims per policy year.

We will not pay:

1. Replacing undamaged rim(s) just to create a matching set.
2. Loss or damage that is already covered by a manufacturer's warranty or recall, or damage caused by skipping regular manufacturer-required maintenance.

3. Worsened damage (like rust or corrosion) caused by delaying your report to us or leaving the vehicle in a waterlogged area.
4. Loss or damage resulting from aging, rust, punctures, bulges, or natural wear and tear. This includes uneven tire wear caused by bad alignment, poor wheel balancing, or failing suspension parts (like shock absorbers or wheel bearings).
5. Cosmetic scratches or chips that do not affect how the rim(s) functions.
6. Loss or damage resulting from illegal acts, fraud, or aggressive driving like racing or rallying.
7. Loss or damage to other parts or accessories of the vehicle that was caused by the broken rim(s).
8. Loss or damage to aftermarket or different rims, unless you informed us about the new rims beforehand and we added them through endorsement to your policy.
9. Any damage that happens within the first 15 days of buying this cover, or within 15 days of renewing a policy after a gap in policy coverage.

15. Cyber Secure

We will pay for any loss, damage, injury, or liability (including the cost of defending a legal claim or action) that arises directly or indirectly from the hacking of your vehicle systems.

Cover Conditions

1. You report the cyber incident by calling the national helpline number 1930 or report it online through the National Cyber Crime Reporting Portal. Where applicable, such incidents must also be reported to CERT-In (Indian Computer Emergency Response Team) as per regulatory requirements.
2. You submit supporting records such as remote command history, login activity, or access logs, along with a report from the vehicle manufacturer (OEM) or an authorised service station confirming unauthorised access to your vehicle system or compromise of its software.
3. We reserve the right to assess and verify whether such hacking has occurred before accepting the claim.



Product UIN

IRDAN171RPMT0001V01202627

We will not pay:

1. Any claim arising from a cyber attack that was committed, attempted, or is alleged to have occurred before the Policy start date mentioned in the Policy Schedule.
2. Any loss arising due to war or cyber terrorism.
3. Any cyber loss that is not related to or connected with the insured vehicle.
4. Any unproven or unexplained loss.
5. Any loss resulting from any act, error, or omission by you, your family members, or your driver.

16. Key Secure

We will secure the vehicle's locks and keys from the loss or damage as per below mentioned cases:

We will pay:

1. **The cost, if the key is lost, stolen, or damaged**
 - a. **New Key:** Replacing it with a new key.
 - b. **Reprogramming:** Pairing the new key with your car.
 - c. **Security Reset:** Resetting the immobilizer or electronic security so the old/lost key cannot be used to steal the car.
 - d. **Deactivation or blocking** of the lost or stolen key.
1. **The cost, If Your vehicle is Broken Into:**
 - a. **New Locks and Keys:** New locks and keys (including the labour charges to install them).
 - b. **Security Reset:** Reprogramming the electronics to ensure the new locks work and old keys are blocked.
 - c. **Deactivation or blocking** of the lost or stolen key.

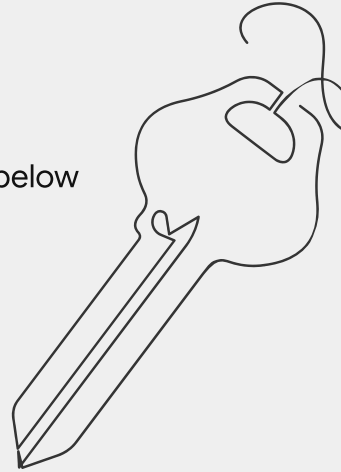

Cover Conditions: Applicable for coverage only through our Garage Network or OEM Network.

Product UIN

IRDAN171RPMT0001V01202627

We will not pay if the loss happened due to your own "gross negligence" (e.g., leaving the keys in the ignition of an unlocked car) or a deliberate act.

17. Fuel Mix-Up Cover

We will pay for the expenses in case of incorrect refuelling of the vehicle.

Cover Conditions:

1. We will cover the cost of:
 - i. Draining and flushing the fuel tank.
 - ii. Cleaning of fuel lines, filters and injectors directly affected by misfuelling.
 - iii. Repair/replacement of damaged parts due to misfuelling.
 - iv. Reimburse the cost you spent on the wrong fuel
 - v. Towing charges to the nearest Garage Network or OEM Network.
 - vi. Cover for AdBlue or Diesel Exhaust fluid contamination for diesel emission vehicles.
2. Applicable up to the number of claims specified in Your Policy Schedule.
3. Applicable only if the vehicle is repaired at our Garage Network or OEM Network.
4. Any claim under this cover **will not impact** Your No Claim Bonus/ Super No Claim Bonus.

We will not pay:

1. For any consequential loss or damage that occurs to any component if you kept running the vehicle even after being informed about the misfuelling.
2. If the misfuelling was caused by any deliberate, wilful or malicious act.
3. If there is no direct physical damage because of the misfuelling like Diesel Particulate Filter (DPF) clogging, regeneration failure, malfunction or warning indications.

18. Re-Coat Cover

We will pay or the cost of re-application of coatings (PPF / Ceramic / Underbody Anti-Rust) in case there is damage to the body panel of the vehicle in an accident.

Cover Conditions:

1. Applicable only if there is an admissible claim under “Section 1: Own Damage” in this policy.
2. We will only re-apply damaged coating.

We will not pay:

1. Any loss or damage already covered under a manufacturer’s warranty, recall campaign, or arising from routine maintenance or failure to carry out required maintenance as specified by the manufacturer.
2. Any loss or damage due to normal wear and tear, improper use.
3. For any consequential loss or damage.

19. Emergency Travel & Stay

In case you are stuck because of an Insured event and your vehicle is immobile and unusable because of this event.

We will pay for your and the co-passenger's overnight stay and taxi charges to reach your place of residence or the nearest city.

Cover Conditions:

1. The Insured event is more than **50 kilometres** away from your residence.
2. Applicable only if there is an admissible claim under “Section 1: Own Damage” in this policy.
3. You must submit original documents and proof of expenses incurred.

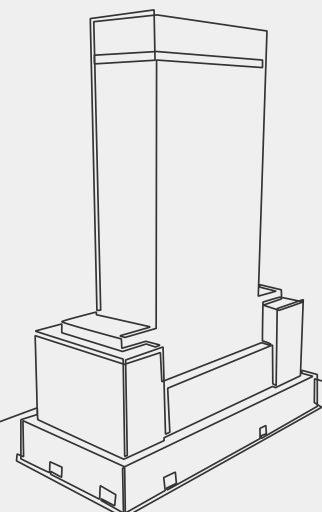

20. InstaCash

We will pay a daily amount (as shown in your Policy Schedule) for every full 24 hours that your vehicle is undergoing repair.

Cover Conditions:

1. Applicable only if there is an admissible claim under “Section 1: Own Damage” in this policy.
2. Applicable only if the vehicle is repaired at our Garage Network or OEM Network.
3. In case of Total Loss, Constructive Total Loss, or Theft, we will pay the daily amount for a maximum of 15 days during the Policy Period. In all other cases, we will pay the daily amount for the number of days specified in the Policy Schedule or the actual number of days required for repair of your vehicle, whichever is lower.
4. Your entitlement to the daily allowance will start from the later of the next calendar day after the vehicle is taken to the garage for repair or the date of survey of the vehicle, and will end on the day the garage informs you to collect the repaired vehicle.

We will not pay

1. If the claim is to repair or replace the windshield/glass only.
2. If the repair time relates to damages that are not covered under “Section 1: Own Damage” of the Policy.

Deductible:

For every claim, you will be required to bear the deductible days specified in the Policy Schedule. We will not pay this portion of the claim.

21. Roadside Assistance

We will arrange Road Side Assistance services through our authorised service provider, in the event the insured vehicle is immobilised due to breakdown or accident, during the Policy Period and within the Covered Area (National highways, state highways and motorable roads of cities across India).

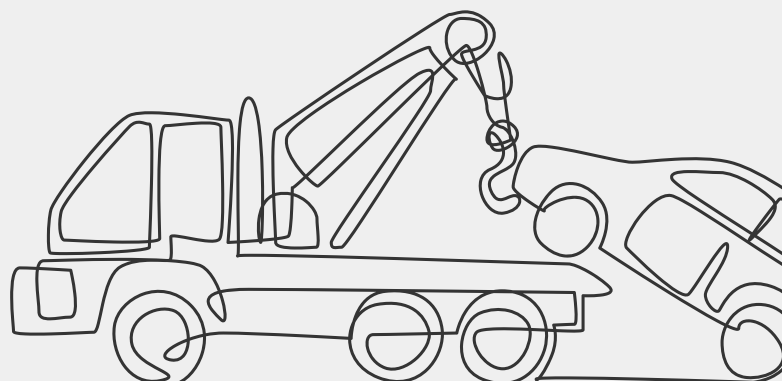

All services are provided on a best-effort basis and subject to the terms, conditions, and limitations specified under each benefit.

1. Breakdown Assistance over Phone

In the event of a vehicular issue, we will provide telephonic assistance to help assess the nature of the problem and guide the Insured on possible remedial actions.

2. On-site Repair

If the insured vehicle is immobilised due to a minor mechanical or electrical breakdown that can be repaired at the location without dismantling, we will arrange for a technician to attend to the vehicle.

- a. You do not have to pay the cost of technician dispatch and labour charges.
- b. The cost of spare parts, consumables, or any additional materials shall be borne by you.

3. Flat Tyre Assistance

If the insured vehicle is immobilised due to a flat tyre, we shall arrange for a technician to replace the flat tyre with the available spare tyre.

- a. If a spare tyre is not available, the flat tyre shall be taken to the nearest repair facility and refitted.
- b. All costs relating to repair, transportation, and consumables shall be borne by you.

4. Battery Jump Start

If the insured vehicle is immobilised due to a discharged battery, the Company shall arrange for a technician to provide jump-start assistance.

- a. You do not have to pay the labour & service charges.
- b. The cost of battery replacement, charging, or any related consumables shall be borne by you.

5. Emergency Fuel Delivery

If the insured vehicle runs out of fuel, the Company shall arrange delivery of up to 5 litres of fuel at the breakdown location.

- a. You do not have to pay for the cost of delivery.
- b. The cost of fuel shall be borne by you at prevailing market rates.

6. Key Assistance

In the event the keys of the insured vehicle are lost, broken, or locked inside the vehicle:

- a. We will arrange for a locksmith to unlock the vehicle, subject to verification of ownership.
- b. Alternatively, we shall arrange retrieval and delivery of spare keys from the Insured's residence or office.
- c. You do not have to pay the cost of such retrieval and delivery for a distance of up to 50 kilometres. Any distance beyond 50 kilometres shall be provided on a chargeable basis and shall be borne by you.

7. Towing

If the insured vehicle cannot be repaired on-site or is immobilised due to an accident, we shall arrange towing of the vehicle to the nearest workshop or a location opted by you.

- a. You do not have to pay for the towing charges for up to 25 kilometres from the breakdown location. Any distance beyond 25 kilometres shall be chargeable to the Insured as per applicable rates.
- b. Additional expenses such as toll charges, parking charges, or special recovery services (including but not limited to use of cranes or specialised equipment) shall be borne by you.

8. Additional Assistance

We will facilitate the below services if the Insured has availed towing services under this Section. These services shall be provided on a chargeable basis and subject to prior consent of the Insured.



Product UIN

IRDAN171RPMT0001V01202627

- a. **Taxi Arrangement:** Arrangement of a taxi for onward travel from the breakdown location or workshop. All charges, including fare, tolls, parking, and waiting time, shall be borne by you. Charges and estimated arrival time shall be confirmed prior to dispatch.
- b. **Hotel Accommodation:** Arrangement of hotel stay at or near the breakdown location or as preferred by you. Room tariff and all incidental expenses, including meals, laundry, internet, and other services, shall be borne by you.
- c. **Repatriation of Repaired Vehicle:** Arrangement for transportation of the repaired vehicle from the workshop to a location specified by you. All associated charges shall be borne by you.
 - 1. Waiting charges shall be applicable in case of delay at the time of vehicle pick-up or drop and shall be charged separately.
 - 2. No cancellation charges shall apply if the request is cancelled at least 90 minutes prior to the scheduled pick-up time.
- d. **Driver Services:** Arrangement of a driver to deliver the repaired vehicle to the Insured's preferred location. The Insured shall ensure sufficient fuel availability and shall bear all charges including driver fees, tolls, parking, and any other applicable expenses.
 - 1. Waiting charges, if any, shall be charged separately.
 - 2. No cancellation charges shall apply if the request is cancelled at least 4 hours prior to the scheduled pick-up time.
- e. **Emergency Message Relay:** Assistance in communicating urgent messages to family members or contacts in case the Insured is unable to do so.

Cover Conditions:

- a. Services shall be provided on a best-effort basis and subject to accessibility, availability of service providers, and prevailing local conditions.
- b. Services may not be available in restricted or prohibited areas or where access to the vehicle is not feasible.

- c. We shall not be liable for any delay or failure in providing services due to circumstances beyond its control, including but not limited to natural calamities, strikes, or regulatory restrictions.
- d. We shall not be responsible for any consequential loss or damage arising from the provision of Road Side Assistance services.
- e. The Insured shall provide valid identification and proof of ownership of the vehicle at the time of availing services, wherever required.
- f. Maximum of 4 services will be provided in a policy year.

22. Accident OPD Cover

We will cover the Emergency Medical Expenses (OPD) for You, the driver, or any passenger injured in the accident of your vehicle during the policy period.

We will pay:

1. For the injuries that happen while getting in, getting out, driving, or riding in the vehicle, provided the treatment is received at a hospital, nursing home, or clinic on an out-patient basis. Covered medical expenses include:
 - a. Doctor consultation fees.
 - b. Prescribed medicines and medical supplies.
 - c. Prescribed Diagnostic procedure & tests (like X-rays or blood work).
 - d. Prescribed Physiotherapy
 - e. Medical Equipment as recommended by the doctor like crutches, wheelchairs, or artificial limbs.
 - f. Ambulance charges, to transport the injured person to a hospital or nursing home.

Cover Conditions:

1. Applicable only if there is an admissible claim under "Section 1: Own Damage" in this policy.

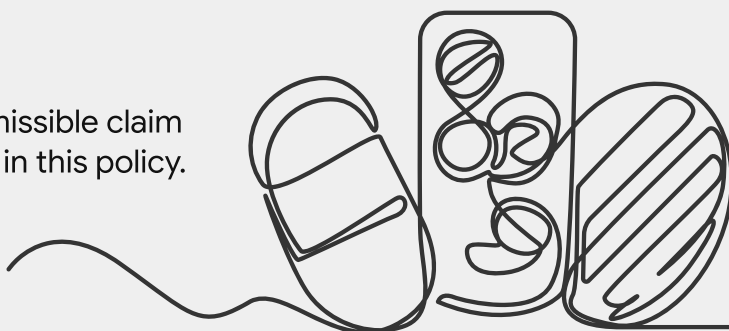

Product UIN

IRDAN171RPMT0001V01202627

2. **Seating Capacity & Limits:** At the time of the accident, the vehicle must not be carrying more passengers than its officially registered limit.
3. **Direct Payouts:** With your approval, we will pay these expenses directly to the injured driver, passenger, or their legal heirs.

We will not pay for:

1. Injuries or medical issues not directly caused by the Insured event.
2. Any expenses that do not have original bills, receipts, and a doctor's prescription.
3. Treatment that starts more than 5 days after the exact date and time of the accident.
4. Injuries caused by intentional self-harm, suicide, attempted suicide, or existing physical conditions.
5. Accidents that happen while the driver is under the influence of alcohol or drugs.
6. Pregnancy or maternity expenses, except for a miscarriage or premature birth caused directly by the accident.
7. Any treatment or part of a treatment that is not "Reasonable and Customary" nor is Medically Necessary.

23. Accident Hospital Cover

We will cover the Emergency Medical hospitalisation Expenses requiring a continuous hospital admission of at least 24 hours, for you, the driver, or any passenger injured in the accident of your vehicle during the policy period.

We will pay for:

1. For the injuries that happen while getting in, getting out, driving, or riding in the vehicle. Covered medical expenses include:
 - a. Room rent.
 - b. Intensive Care Unit (ICU) charges.
 - c. Professional fees for doctors, specialists, nurses, surgeons, and anaesthetists.

- d. Operation theatre (OT) charges.
 - e. Diagnostic tests (such as X-rays, pathology, MRIs, and CT scans).
 - f. Prescribed medicines, drugs, and medical supplies (including anaesthesia, blood, oxygen, patient meals, surgical appliances, and implanted medical devices).
 - g. Physiotherapy recommended by the treating doctor.
 - h. Post-hospitalisation medical expenses for up to 90 days after being discharged, provided it is for the same injury.
2. **Day-Care Procedures:** If an injured person or passenger of the insured vehicle needs a medical or surgical procedure that requires general or local anaesthesia in a hospital or day-care centre, but takes less than 24 hours, we will cover it up to your Sum Insured. However, standard Outpatient Department (OPD) visits are not covered.
 3. **Road Ambulance:** We will pay for ambulance charges up to your Sum Insured to transport the injured person to a hospital or nursing home after the accident. You must use a registered ambulance provider Only.

Cover Conditions:

1. Applicable only if there is an admissible claim under “Section 1: Own Damage” in this policy.
2. **Seating Capacity:** At the time of the accident, the vehicle must not be carrying more passengers than its officially registered limit.
3. **Direct Payouts:** With your approval, we will pay these expenses directly to the injured driver, passenger, or their legal heirs.



We will not pay:

1. Injuries or medical issues not directly caused by the Insured event
2. Any expenses that do not have original bills, receipts, and a doctor's prescription.
3. Injuries caused by intentional self-harm, suicide, attempted suicide, or existing physical defects.
4. Accidents that happen while the driver is under the influence of alcohol or drugs.
5. Pregnancy or maternity expenses, except for a miscarriage or premature birth caused directly by the accident.
6. Any treatment or part of a treatment that does not form part of 'Reasonable and Customary Charges' nor is Medically Necessary.
7. Cosmetic or Plastic Surgery: Expenses for cosmetic or plastic surgery or any treatment to change appearance unless for reconstruction following an Accident, Burn(s) or Cancer or as part of medically necessary treatment to remove a direct and immediate health risk to the insured. For this to be considered a medical necessity, it must be certified by the attending Medical Practitioner.
8. Dental care, unless it is required to fix healthy, natural teeth damaged in the accident.
9. Personal comfort items such as TV charges, phone calls, internet, outside food, cosmetics, toiletries, body care products, or beauty/barber services.
10. Over-the-counter dietary supplements (like but not limited to vitamins and minerals), unless specifically prescribed by a doctor as part of your official hospital or day-care treatment.
11. Investigation & Evaluation:
 - a. Expenses related to any admission primarily for diagnostics and evaluation purposes only are excluded.
 - b. Any diagnostic expenses which are not related or not incidental to the current diagnosis and treatment are excluded.
12. Breach of law: Expenses for treatment directly arising from or consequent upon any Insured Person committing or attempting to commit a breach of law with criminal intent.

Product UIN

IRDAN171RPMT0001V01202627

13. Unproven/Experimental treatment means the treatment including drug experimental therapy which is not based on established medical practice in India, is treatment experimental or unproven
14. Any expenses claimed as Outpatient Department (OPD) emergency medical expenses.

24. HospiCash

We will pay:

A daily amount (as shown in your Policy Schedule) for every full 24 hours that you, the driver, or a passenger spend in the hospital being treated for physical injuries.

Cover Conditions:

1. Applicable only if there is an admissible claim under “Section 1: Own Damage” in this policy.
2. The injury must happen while getting in, getting out, driving, or riding in the insured vehicle during the policy period.
3. The injured person must be officially admitted to the hospital as an inpatient for a minimum of 24 consecutive hours.
4. We will pay double the daily cash amount for every day you or a passenger spends in an Intensive Care Unit (ICU).
5. If you or a passenger spend part of a day in the ICU and part of it in a regular room, we will still pay the double daily cash amount for that entire day.
6. Payouts are subject to the waiting periods mentioned in your Policy Schedule.
7. Seating Capacity: At the time of the accident, the vehicle must not be carrying more passengers than its officially registered limit.
8. Direct Payouts: With your approval, we will pay these expenses directly to the injured driver, passenger, or their legal heirs.

We will not pay:

1. Hospital stays for sicknesses, diseases, or medical conditions that were not directly caused by the car accident.

Product UIN

IRDAN171RPMT0001V01202627

2. Injuries that happen while you or a passenger are committing or attempting to commit a breach of law with criminal intent.
3. For Suicide, attempted suicide, or intentional self-harm.
4. If the driver was under the influence of alcohol or drugs.
5. Hospital stays for old injuries from accidents that happened before this policy started.
6. Injuries or medical issues not directly caused by the Insured event

Deductible:

For every claim, you will be required to bear the deductible days specified in the Policy Schedule. We will not pay this portion of the claim.

25. EV-Battery Secure

We will pay:

The cost of repair or replacement in the event of consequential damage to the Battery, Drive Motor/Electric Motor, Hybrid Electric Vehicle (HEV) System.

Cover Conditions:

1. This will be paid only if the damages arise due to:
 - a. Unexpected power surge while charging the battery
 - b. Water ingress due to flood
 - c. Short circuit, including during mounting, dismounting, or while charging the vehicle
 - d. Spontaneous, unexplained, and uncontrolled electrochemical reactions within the battery cells resulting in explosion, visible flames, or smoke from the battery or Battery Management System (BMS)
2. In case of a claim due to a power surge or water ingress, the damage is supported by diagnostic reports, Battery Management System (BMS) logs, and findings from an authorised service centre.

3. In case of water ingress, there is clear evidence that the vehicle was submerged in water, resulting in damage to the covered components.
4. Applicable only if the vehicle is repaired at our Garage Network or OEM Network.
5. The Health of Traction Battery (HOTB) is maintained as per the manufacturer's prescribed schedule.
6. Applicable up to the number of claims specified in Your Policy Schedule.
7. If a claim paid under this cover is also payable under any other section of this Policy, we will adjust the amount so that the same loss is not paid twice under different covers.

Cover Conditions:

1. Any claim where the vehicle is declared a Total Loss or Constructive Total Loss.
2. Any loss or damage that is already covered under another policy, manufacturer's warranty, or recall campaign.
3. Any claim reported after 3 days from the date of loss or damage. However, we may, at our discretion, accept delayed intimation if valid reasons are provided in writing.
4. Any repairs carried out without our prior approval.
5. Any damage caused due to usage not in line with the owner's manual or beyond manufacturer limits, including overloading, overspeeding, performance modifications, battery health or improper charging not as per OEM guidelines.
6. Any claim where the battery health is below the threshold specified by the manufacturer.
7. Any loss or damage where the battery was already non-functional prior to the incident due to delayed charging or any other reason.
8. Any loss where the vehicle stops due to battery discharge and is not plugged in for charging within 24 hours of stoppage.
9. Any loss or damage to accessories or attachments not supplied as original equipment with the insured vehicle.
10. Any loss or damage due to failure to carry out periodic maintenance as specified by the manufacturer or not performed at an authorised service centre.
11. Any loss or damage caused wilfully, knowingly, or due to negligence by you, your employees, or your family members.

12. Any loss or damage, including corrosion, arising due to delay in informing us or delay in removing the vehicle from a waterlogged area.
13. Any third-party liability for death, bodily injury, or property damage.
14. Any loss or damage to internal combustion engine components of a hybrid vehicle or any component not specifically covered under this benefit.

26. EV Charger Secure

We will pay:

1. For the repair or replacement of:
 - a. Your wall-mounted charger (including uninstallation and reinstallation costs), and/or
 - b. Your portable charger, charging cable as provided by the OEM.
2. The cost of charging your vehicle battery while the damaged charger is being repaired or replaced, subject to submission of bills.

Cover Conditions:

1. In case of replacement, we will provide a charger of the same specification and capacity as recommended by the manufacturer (OEM) and covered under the Policy.
2. Loss is caused due to Perils covered under "Section 1: Own Damage" of the Policy, or
3. Power surge, or improper voltage or current supply
4. The wall-mounted charger, portable charger, and related accessories comply with the safety standards prescribed by the Government of India.
5. The charger is used only for vehicles owned by you or your family members living with you.
6. In case of theft, burglary, housebreaking, or malicious damage, you must inform the police within 24 hours of the incident and submit a police report to us.
7. Any claim made under this cover **will not impact** your No Claim Bonus/Super No Claim Bonus.

We will not pay:

1. Any loss or damage already covered under a manufacturer's warranty, recall campaign, or arising from routine maintenance or failure to carry out required maintenance as specified by the manufacturer.
2. Any charger or accessories that are not repaired by OEM-authorized personnel.
3. Replacement of a charger that is not as per the manufacturer's (OEM) specifications.
4. Any loss or damage caused by manufacturing defects, or by using the charger in a way not recommended in the owner's manual or beyond the manufacturer's specified limits.
5. Any loss or damage to accessories or attachments that are not original equipment or not as per the manufacturer's specifications or configuration.
6. Any third-party liability for injury, death, or property damage arising from the use of the charger or related accessories.
7. Any loss or damage if the charger or accessories are used for charging devices other than the insured vehicle.
8. Any use of the charger or accessories for commercial purposes.
9. Any loss or damage due to normal wear and tear, improper use, or incorrect fitting of the charger or related accessories.
10. For any consequential loss or damage.
11. Any damage caused by internal electrical or mechanical breakdown or failure.
12. Theft where there is no evidence of forcible entry.
13. Minor issues such as noise, vibration, or heating that do not affect the normal functioning of the equipment.

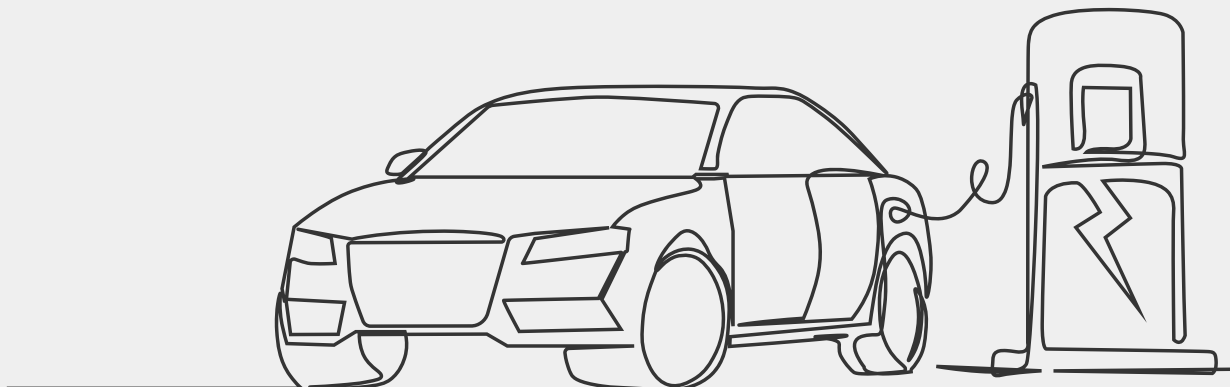

27. EV Charger - Liability Cover

We will pay for your legal liability arising out of the use of your wall-mounted charger installed at a specified location, and/or your portable charger leading to death or bodily injury to a third party and/or loss or damage to a third party's property.

Cover Conditions:

1. The charger must be approved and certified by the vehicle manufacturer.
2. You must ensure that the wall-mounted charger is installed securely by a qualified person, in line with the manufacturer's installation guidelines and applicable electrical safety laws and regulations.
3. The charger must be used only for charging the insured vehicle or any other compatible electric vehicle owned by you or your family.
4. Any claim made under this cover **will not impact** your No Claim Bonus/ Super No Claim Bonus

We will not pay:

1. Any loss or damage that is already covered under a manufacturer's warranty, recall campaign, or is part of regular maintenance or lack of required maintenance as specified by the manufacturer.
2. For damage to property that belongs to you or your family, or is in your care, custody, or control.
3. For death of or bodily injury to you, your family members, or your driver.
4. Any use of the charger for commercial purposes.
5. Any loss that is not related to or arising from your charger.
6. Any loss caused due to improper or unsafe installation of the charger.
7. Any loss resulting from wilful disregard of safety instructions or statutory requirements.

28. EV Charger - Home Secure

We will pay, in case of damage to your home contents, caused by a fire resulting from use of EV Charger.

Cover Conditions:

1. The damaged charger must be officially approved and certified by the vehicle's manufacturer.
2. The wall charging equipment must be safely and securely installed by a qualified professional, strictly following the manufacturer's manual and local electrical safety laws/regulations.
3. Making a claim under this specific cover will not impact your No Claim Bonus (NCB)/ Super NCB.

We will not pay:

1. If you failed to follow the manufacturer's instructions, maintenance requirements, or safety warnings included with your charger (in the documentation given for the charger).
2. If you are using the charger for business/commercial purposes, or using it to charge a different, non-compatible electric vehicle owned by you or your family.

29. Legal Assist

We will pay:

1. For the following in case of an Insured event:
 - a. Your lawyer's professional fees.
 - b. Court fees for the first court where the case is filed.
 - c. Stamp duty charges.
 - d. Any other expenses related to that first court, except for bail money (which is not covered).

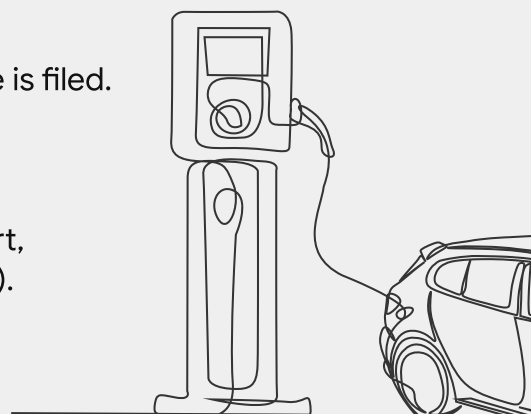

Product UIN

IRDAN171RPMT0001V01202627

2. If we pay under the point above (Section 29.1) then we will pay miscellaneous expenses incurred as a result of the accident.

Cover Conditions:

1. You must report the accident to us within 7 days of occurrence of the accident.
2. You must file a Police First Information Report (FIR)
3. You must submit bills & receipts, to support the expenses made by you.
4. The accident must happen within the geographical limits specified in your policy.
5. There must be an admissible claim under the Policy for liability towards Third party. If at any time a Claim is deemed not to be covered under the Policy, then all such amounts which have been paid by Us under this cover must be returned to Us.
6. If you transfer the ownership of the vehicle, this cover transfers to the new owner.
7. Any assistance under this cover cannot be construed as an admission of liability by Us under Section 2: Liability to Third Parties of this Policy.

We will not pay:

1. If the vehicle is not being used or driven in accordance with the applicable laws.
2. For any legal proceedings that are fake, fraudulent, exaggerated, or you have made misrepresentations.
3. If at the time of the accident, the person driving the Insured vehicle:
 - a. Was disqualified from driving.
 - b. Did not have a valid driving licence.
 - c. Failed to comply with any laws relating to the vehicle's ownership or use.
4. For any deliberate, willful or intentional non-compliance of any statutory provision proved/established in the court judgement
5. If the person driving the Insured vehicle at the time of accident was under the influence of alcohol, drugs, or other intoxicants.
6. For any claim arising out of any contractual liability.

Product UIN

IRDAN171RPMT0001V01202627

7. For legal proceedings between you and your family members arising out of the accident.
8. For fines, penalties, or damages you are ordered to pay.
9. For legal costs in a criminal case where you / driver of the Insured vehicle at time of accident, are found guilty.
10. For legal expenses not related to the accident or for getting your vehicle released.
11. For expenses in any court other than the very first court to hear the case.

30. Pay As You Drive

This cover is based on the actual usage of your vehicle, measured in kilometres as per the odometer reading during the Policy Period.

Your vehicle will be covered until:

- You reach the number of kilometres you have opted for, or
- The expiry of the Own Damage section of the Policy as mentioned in the Policy Schedule,
- whichever occurs earlier.

Pay As You Drive: Top-Up

You may purchase additional kilometres before your existing kilometer limit is exhausted by paying the applicable premium.

You can opt for such top-ups multiple times during the Policy Period.

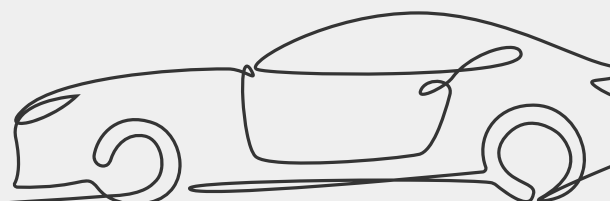

Carry Forward of Unused Kilometres

You may carry forward unused kilometres to your renewed Policy, subject to the following:

- You must opt for this cover again at the time of renewal. If you do not opt for this cover on renewal, any unused kilometres will lapse at the end of the Policy Period and cannot be used later.
- You must renew the Policy with us before the expiry of this cover.
- The total number of kilometres carried forward will not exceed 5,000 kilometres.

Cover Conditions:

1. The odometer of your vehicle remains functional at all times during the Policy Period, and the kilometres driven can be clearly verified through its readings.
2. In case the odometer becomes non-functional or faulty, you inform us immediately and do not use the vehicle until it is repaired.
3. There is no tampering with the odometer or its readings at any time during the Policy Period.
4. The kilometres driven are calculated based on the difference between the odometer reading declared at Policy inception/renewal and the reading at any point during the Policy Period or at expiry of the Own Damage section.
5. At the time of a claim, your total usage does not exceed the kilometres opted at inception along with any additional kilometres purchased through top-ups.
6. The above kilometer limit condition will not apply in case of:
 - a. Total Loss, Constructive Total Loss or theft of the vehicle where odometer reading cannot be determined
 - b. Claims under Section 2 (Liability to Third Party) and Section 3 (Personal Accident to Owner-Driver)
7. If you have exhausted your purchased kilometres and have not topped up in time, your claim will still be considered provided:
 - a. The excess usage does not exceed 100 kilometres at the time of the accident, and
 - b. You pay the applicable premium for the additional kilometres.

8. In case the odometer stops working, loses data, or readings are deleted due to a covered peril under “Section 1: Own Damage”, the claim is assessed based on our investigation or forensic review, and kilometer entitlement may be reinstated proportionately for the remaining Policy Period.
9. In case of transfer of ownership and Policy during the Policy Period, the new owner is eligible to use the remaining unused kilometres.
10. At the time of renewal, you opt for this cover again and allow inspection of the vehicle if the purchased and top-up kilometres have been exhausted before expiry of the Own Damage section.

31. Extension of Geographical Area (IMT 1)

In consideration of the payment of an additional premium and subject to the terms, exceptions, conditions and limitations of this Policy, it is hereby understood and agreed that notwithstanding anything contained in this Policy to the contrary, the Geographical Area in this Policy shall be deemed to include as specified in the Policy Schedule/Endorsement. It is further specifically understood and agreed that such geographical extension excludes cover for damage to the insured vehicle / injury to its occupants / third party liability in respect of the insured vehicle during sea voyage / air passage for the purpose of ferrying the insured vehicle to the extended geographical area.

32. Discount for Membership of Recognised Automobile Associations (IMT 8)

In consideration of the insured’s membership to a recognised automobile association as specified in the Policy Schedule/Endorsement, and subject to the terms, exceptions, conditions and limitations of this Policy, it is hereby understood and agreed that a discount in premium, limited to 5% of the Gross Own Damage Premium and applicable only for memberships as per the approved list, is allowed to the insured for the period of insurance as stated in the Policy Schedule/Endorsement.

It is further understood and agreed that if the insured ceases to be a member of the above-mentioned association during the currency of this Policy, the insured shall immediately notify the insurer accordingly and refund to the insurer a proportionate amount of the discount allowed on this account for the unexpired period of the cover.

Subject otherwise to the terms, exceptions, conditions and limitations of this Policy.

33. Discount for Vintage Cars (IMT 9)

In consideration of the insured vehicle having been certified as a Vintage Car by the Vintage and Classic Car Club of India, and subject to the terms, exceptions, conditions and limitations of this Policy, it is hereby understood and agreed that a discount of 25% on the Gross Own Damage Premium and 50% on the Third Party Premium is allowed to the insured, as specified in the Policy Schedule/Endorsement.

It is further understood and agreed that in the event of certification as a Vintage Car during the currency of the Policy, such discount shall be allowed on a pro-rata basis for the unexpired period of the Policy, as recorded in the Policy Schedule/Endorsement.

Subject otherwise to the terms, exceptions, conditions and limitations of this Policy.

34. Vehicles Laid Up (Lay Up Period Declared) (IMT 11.A)

In consideration of the insured having declared that the insured vehicle shall remain laid up in a garage and not in use for the period as specified in the Policy Schedule/Endorsement, and as declared to the Regional Transport Office (RTO) with corresponding changes recorded in the Registration Certificate (RC), and subject to the terms, exceptions, conditions and limitations of this Policy, it is hereby understood and agreed that during such declared lay-up period, all liability of the insurer under this Policy in respect of the insured vehicle shall remain suspended, save only in respect of loss or damage to the insured vehicle caused by fire, explosion, self-ignition, lightning, burglary, housebreaking, theft, riot, strike, malicious damage, terrorism, storm, tempest, flood, inundation, earthquake or such other perils as covered under the Policy.

It is further understood and agreed that, in consideration of such lay-up:

- a. The insurer shall allow a pro-rated adjustment in premium for the period of lay-up, and such adjustment shall be reflected in the Policy Schedule/Endorsement or adjusted against the next renewal premium. The No Claim Bonus (if any) shall be calculated on the renewal premium after giving effect to such adjustment; or
- b. The period of insurance under this Policy shall stand extended by a duration equivalent to the declared lay-up period, subject to the terms specified in the Policy Schedule/Endorsement and payment of applicable premium, if any, for restricted cover during such period.

The applicable option shall be as specified in the Policy Schedule/Endorsement

Subject otherwise to the terms, exceptions, conditions and limitations of this Policy.

35. Vehicles Laid Up (Lay Up Period Not Declared) (IMT 11.B)

In consideration of the insured having declared that the insured vehicle is laid up in a garage and not in use, as recorded in the Policy Schedule/Endorsement and as declared to the Regional Transport Office (RTO) with corresponding changes recorded in the Registration Certificate (RC), and subject to the terms, exceptions, conditions and limitations of this Policy, it is hereby understood and agreed that with effect from the date of such declaration as specified in the Policy Schedule/Endorsement, the liability of the insurer under this Policy in respect of the insured vehicle shall remain suspended until such suspension is revoked by you and duly endorsed by the insurer.

It is further understood and agreed that during the period of such suspension, the Policy shall respond only in respect of loss or damage to the insured vehicle caused by fire, explosion, self-ignition, lightning, burglary, housebreaking, theft, riot, strike, malicious damage, terrorism, storm, tempest, flood, inundation, earthquake or such other perils as covered under the Policy.

It is further understood and agreed that upon revocation of such lay-up status:

- a. The insurer shall allow a pro-rated adjustment in premium for the period during which the vehicle remained laid up, and such adjustment shall be reflected in the Policy Schedule/Endorsement or adjusted against the next renewal premium. The No Claim Bonus (if any) shall be calculated on the renewal premium after giving effect to such adjustment; or
- b. The period of insurance under this Policy may, at the option of the insured and subject to insurer's approval, be extended by a duration equivalent to the period of suspension, in accordance with the terms specified in the Policy Schedule/Endorsement.

The applicable option shall be as specified in the Policy Schedule/Endorsement.

Subject otherwise to the terms, exceptions, conditions and limitations of this Policy.

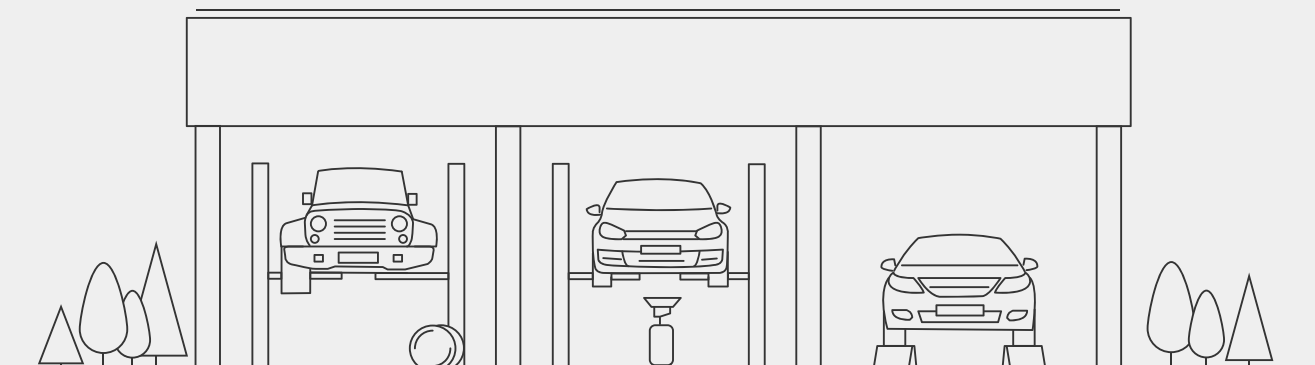

36. Termination of Undeclared Period of Vehicle Laid Up (IMT 11.C)

In consideration of the insured having declared the removal of the lay-up status of the insured vehicle, as recorded in the Policy Schedule/Endorsement and as declared to the Regional Transport Office (RTO) with corresponding updates recorded in the Registration Certificate (RC), and subject to the terms, exceptions, conditions and limitations of this Policy, it is hereby understood and agreed that the insurance under this Policy in respect of the insured vehicle shall stand reinstated in full with effect from the date as specified in the Policy Schedule/Endorsement.

It is further understood and agreed that the provisions of Endorsement IMT 11(B) attaching to this Policy shall stand cancelled from the effective date of such reinstatement.

It is further agreed that in consideration of the period during which the insured vehicle remained out of use:

- a. The insurer shall allow a pro-rated adjustment in premium for such period, and such adjustment shall be reflected in the Policy Schedule/Endorsement or adjusted against the next renewal premium. The No Claim Bonus (if any) shall be calculated on the renewal premium after giving effect to such adjustment; or
- b. The period of insurance under this Policy may, at the option of the insured and subject to insurer's approval, be extended by a duration equivalent to the period during which the vehicle remained laid up, in accordance with the terms specified in the Policy Schedule/Endorsement.

The applicable option shall be as specified in the Policy Schedule/Endorsement.

Subject otherwise to the terms, exceptions, conditions and limitations of this Policy.

Cover Conditions for IMT 11.A, 11.B and 11.C

Return of premium or extension of policy period in lieu thereof, on account of lay-up of vehicles, both in respect of Liability Only Policies and Package Policies, will be available provided

- i. The vehicle is not undergoing repairs during lay-up as a result of an event giving rise to a claim under the policy
- ii. previous notice in writing has been given to the insurer by recorded delivery
- iii. the certificate of insurance has been returned to the insurer and
- iv. the period of lay-up / suspension of policy shall not extend beyond twelve months from the expiry date of the policy period in which the lay-up has commenced. In case the period extends beyond stated cap, the policy expires.

- v. Vehicles laid up in garage and not in use for a period of not less than two consecutive months
- vi. No return of premium or extension of policy period in lieu thereof is to be allowed for lay-up when the permits/Registration for the vehicle is temporarily withheld or suspended by the Government

37. Discount for Specially Designed/Modified Vehicles for the Specially Abled Persons (IMT 12)

In consideration of the insured vehicle being specially designed and/or modified for use by Specially Abled Persons and subject to the terms, exceptions, conditions and limitations of this Policy, it is hereby understood and agreed that a discount of 50% on the Gross Own Damage Premium is allowed to the insured.

It is further understood and agreed that such discount shall be applicable only where the classification of the insured vehicle is recorded as "Invalid Carriage" in the Registration Certificate (RC), duly approved and endorsed by the Regional Transport Office (RTO), and as specified in the Policy Schedule/Endorsement.

Subject otherwise to the terms, exceptions, conditions and limitations of this Policy.

38. Use of Vehicle within Insured's Own Premises (IMT 13)

In consideration of the insured having declared that the use of the insured vehicle is confined solely to the insured's own premises, as specified in the Policy Schedule/Endorsement, and subject to the terms, exceptions, conditions and limitations of this Policy, it is hereby understood and agreed that a discount of 33.33% on the Gross Own Damage Premium and 33.33% on the Third Party Premium is allowed to the insured based on such declaration.

It is further understood and agreed that the insurer shall not be liable in respect of the insured vehicle whilst it is being used elsewhere than within the insured's premises, except where the vehicle is specifically required for a mission to fight a fire.

For the purpose of this endorsement, "use confined to own premises" shall mean use only within the insured's premises to which the public has no general right of access.

It is further understood and agreed that in the event of any use of the insured vehicle outside the insured's premises other than as specified above, the insured shall immediately notify the insurer, and the insurer shall be entitled to recover a proportionate amount of the premium discount allowed under this endorsement for the period of such use.

Subject otherwise to the terms, exceptions, conditions and limitations of this Policy.

39. Personal Accident Cover to You or any named person other than paid driver or cleaner (IMT 15)

In consideration of the payment of an additional premium and subject to the terms, exceptions, conditions and limitations of this Policy, it is hereby agreed and understood that, We undertake to pay compensation on the scale provided below for bodily injury as hereinafter defined, sustained by You and any other person named in the Policy Schedule, in direct connection with the insured vehicle or whilst mounting and dismounting from or travelling in the insured vehicle and caused by violent, accidental, external and visible means which independently of any other cause shall within six calendar months of the occurrence of such injury result in:

Nature of injury	Scale of compensation
(i) Death	100%
(ii) Loss of two limbs or sight of two eyes or one limb and sight of one eye.	100%
(iii) Loss of one limb or sight of one eye	50%
(iv) Permanent total disablement from injuries other than named above	100%

Provided always that

1. Compensation shall be payable under only one of the items (i) to (iv) above in respect of any such person, arising out of any one occurrence and Our total liability, shall not in the aggregate exceed the sum insured specified in the Policy Schedule during Policy year, in respect of any such person.
2. No compensation shall be payable in respect of death or injury, directly or indirectly, wholly or in part, arising or resulting from or traceable to
 - a. intentional self injury, suicide or attempted suicide, physical defect or infirmity or
 - b. an accident happening whilst such a person is under the influence of intoxicating liquor or drugs.

3. Such compensation shall be payable only with Your approval and directly to the injured person or his/her legal representative(s), whose receipt shall be a full discharge in respect of the injury of such person.
4. The insurer's liability shall be limited to the number of persons as opted by you as specified in the Policy Schedule/Endorsement, on a per annum basis.

40. Personal Accident to Unnamed Passengers other than You and the Paid driver and Cleaner (IMT 16)

In consideration of the payment of an additional premium and subject to the terms, exceptions, conditions and limitations of this Policy, it is hereby understood and agreed that We undertake to pay compensation on the scale provided below for bodily injuries hereinafter defined sustained by any passenger other than You and/or Your paid driver, attendant or cleaner and/or a person in Your employment, coming within the scope of the Employees Compensation Act, 1923 and subsequent amendments of the said Act and engaged in and upon Your service at the time such injury is sustained, whilst mounting into, dismounting from or travelling in but not driving the insured motor car and caused by violent, accidental, external and visible means which independently of any other cause shall within six calendar months of the occurrence of such injury result in :

Nature of injury	Scale of compensation
(i) Death	100%
(ii) Loss of two limbs or sight of two eyes or one limb and sight of one eye.	100%
(iii) Loss of one limb or sight of one eye	50%
(iv) Permanent total disablement from injuries other than named above	100%

Provided always that

1. Compensation shall be payable under only one of the items (i) to (iv) above in respect of any such person, arising out of any one occurrence and Our total liability, shall not in the aggregate exceed the sum insured specified in the Policy Schedule during Policy year, in respect of any such person.
2. No compensation shall be payable in respect of death or injury, directly or indirectly, wholly or in part, arising or resulting from or traceable to
 - a. intentional self injury, suicide or attempted suicide, physical defect or infirmity or
 - b. an accident happening whilst such a person is under the influence of intoxicating liquor or drugs.
3. Such compensation shall be payable only with Your approval and directly to the injured person or his/her legal representative(s), whose receipt shall be a full discharge in respect of the injury of such person.
4. The insurer's liability shall be limited to the number of persons as opted by you as specified in the Policy Schedule/Endorsement, on a per annum basis.

41. Personal Accident Cover to Paid Drivers, Cleaners and Conductors (IMT 17)

In consideration of the payment of an additional premium, as specified in the Policy Schedule/Endorsement, and subject to the terms, exceptions, conditions and limitations of this Policy, it is hereby understood and agreed that the insurer undertakes to pay compensation on the scale provided below for bodily injury sustained by any paid driver, cleaner and/or conductor in the employment of the insured, in direct connection with the insured vehicle, whilst mounting into, dismounting from or travelling in the insured vehicle, and caused by violent, accidental, external and visible means which independently of any other cause shall, within six calendar months of the occurrence of such injury, result in the following:

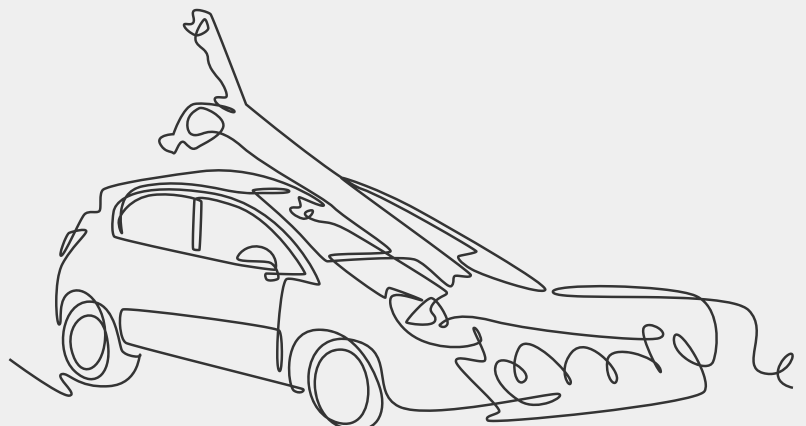

Product UIN

IRDAN171RPMT0001V01202627

Nature of injury	Scale of compensation
(i) Death	100%
(ii) Loss of two limbs or sight of two eyes or one limb and sight of one eye.	100%
(iii) Loss of one limb or sight of one eye	50%
(iv) Permanent total disablement from injuries other than named above	100%

Provided always that

1. Compensation shall be payable under only one of the above items in respect of any such person arising out of any one occurrence up to the limit mentioned in your Policy Schedule per person during any one period of insurance.
2. No compensation shall be payable in respect of death or injury, directly or indirectly, wholly or in part, arising or resulting from or traceable to
 - a. intentional self-injury, suicide or attempted suicide, physical defect or infirmity; or
 - b. an accident happening whilst such a person is under the influence of intoxicating liquor or drugs.
3. Such compensation shall be payable only with the approval of the insured named in the Policy and directly to the injured person or their legal representative(s), whose receipt shall be a full discharge in respect of such injury.
4. The insurer's liability shall be limited to the number of persons as opted by you as specified in the Policy Schedule/Endorsement, on a per annum basis.

Subject otherwise to the terms, exceptions, conditions and limitations of this Policy.

42. Cover for Vehicles Imported Without Customs Duty (IMT 19)

In consideration of the terms, conditions, limitations and exceptions of this Policy, it is hereby understood and agreed that notwithstanding anything to the contrary contained herein, in the event of loss of or damage to the insured vehicle and/or its accessories necessitating the supply of a part not obtainable from stocks held in the country in which the insured vehicle is held for repair, or in the event of the insurer exercising its option to settle the claim on a cash basis, the liability of the insurer in respect of any such part shall be limited as follows:

- a.
 - i. The price quoted in the latest catalogue or price list issued by the manufacturer or its agent for the country in which the insured vehicle is held for repair, less depreciation as applicable under the Policy; or
 - ii. Where no such catalogue or price list exists, the price prevailing at the manufacturer's works, plus the reasonable cost of transport (otherwise than by air) to the country in which the insured vehicle is held for repair, and the applicable import duty, less depreciation as per the Policy;
- b. The reasonable cost of fitting such parts.

It is further understood and agreed that the total liability of the insurer under this Endorsement shall in no case exceed the Insured Declared Value (IDV) of the vehicle as specified in the Policy Schedule/Endorsement.

Subject otherwise to the terms, conditions, limitations and exceptions of this Policy.

43. Reduction in the limit of Liability for Property damage (IMT 20)

It is hereby understood and agreed that notwithstanding anything to the contrary contained in the policy and subject otherwise to the terms, conditions, limitations and exceptions of the policy, Our liability is limited to Rs. 6000/- (Rupees six thousand only) for damage to property other than the property belonging to You or held in trust or in Your custody or control. In consideration of this, we have allowed discount in premium as specified in the Policy Schedule/Endorsement.

44. Voluntary Deductible (IMT 22A)

In consideration of the insured having opted for a voluntary deductible under “Section 1: Own Damage” of this Policy, as specified in the Policy Schedule/Endorsement, and subject to the terms, conditions, limitations and exceptions of this Policy, it is hereby understood and agreed that a reduction in premium has been allowed in accordance with such option.

It is further understood and agreed that the insured shall bear, under “Section 1: Own Damage” of the Policy, in respect of each and every event (including an event giving rise to a total loss/constructive total loss), a voluntary deductible equivalent to the percentage of the claim amount as specified in the Policy Schedule/Endorsement of the admissible claim amount, or any lower expenditure incurred.

It is further understood and agreed that such voluntary deductible shall apply only to Own Damage claims and shall be over and above the applicable compulsory deductible under the Policy.

If the expenditure incurred by the insurer includes any amount for which the insured is responsible under this Endorsement, such amount shall be reimbursed by you to the insurer forthwith.

For the purpose of this Endorsement, the expression “event” shall mean an event or a series of events arising out of one cause in connection with the insured vehicle in respect of which indemnity is provided under this Policy.

Subject otherwise to the terms, conditions, limitations and exceptions of this Policy.

45. Electrical /Electronic fittings (Items fitted in the vehicle but not included in the manufacturer’s listed selling price of the vehicle) (IMT 24)

In consideration of the payment of an additional premium specified in the Policy Schedule and notwithstanding anything to the contrary contained in the policy, it is hereby understood and agreed that We will pay You against loss of or damage to such electrical and/or electronic fitting(s) as specified in the Policy Schedule, whilst it/these is/are fitted in or on the vehicle insured, where such loss or damage is occasioned by any of the perils mentioned in Section.1 Loss or damage to the vehicle - (OWN DAMAGE)” of the policy.

We shall, however, not be liable for loss of or damage to such fitting(s) caused by/as a result of mechanical or electrical breakdown.

Provided always that Our liability shall not exceed the Insured's Declared Value (IDV) of the item.

Subject otherwise to the terms, conditions, limitations and exceptions of this Policy.

46. CNG/LPG Kit in Bi-Fuel System (Own Damage Cover for the Kit) (IMT 25)

In consideration of the payment of an additional premium, as specified in the Policy Schedule/Endorsement, and subject to the terms, conditions, limitations and exceptions of "Section 1: Own Damage" of this Policy, it is hereby understood and agreed that notwithstanding anything to the contrary contained in this Policy, the insurer shall indemnify the insured against loss of or damage to the CNG/LPG kit or bi-fuel system, duly approved by the Regional Transport Authority (RTA) and fitted in the insured vehicle, arising out of accidental loss or damage to the insured vehicle.

It is further understood and agreed that the liability of the insurer under this Endorsement shall be limited up to the Sum Insured declared for the CNG/LPG kit or bi-fuel system as specified in the Policy Schedule/Endorsement.

Subject otherwise to the terms, conditions, limitations and exceptions of this Policy.

47. Fire and/or Theft risks only (IMT 26)

Fire and Theft only:

It is hereby understood and agreed, notwithstanding anything to the contrary contained in the policy, that Section 2 of the Policy is deemed to be cancelled and under Section 1 of the Policy, We shall only be liable to pay You against loss or damage by fire, explosion, self-ignition, lightning and/or burglary, housebreaking, theft and riot, strike, malicious damage, terrorism, storm, tempest, flood, inundation and earthquake whilst the vehicle is laid up in garage and not in use.

Fire Only:

It is hereby understood and agreed, notwithstanding anything to the contrary contained in the policy, that Section 2 of the Policy is deemed to be cancelled and under Section 1 of the Policy, We shall only be liable to pay You against loss or damage by fire, explosion, self-ignition, lightning and/or riot, strike, malicious damage, terrorism, storm, tempest, flood, inundation and earthquake whilst the vehicle is laid up in garage and not in use.

Theft Only:

It is hereby understood and agreed, notwithstanding anything to the contrary contained in the policy, that Section 2 of the Policy is deemed to be cancelled and under Section 1 of the Policy, We shall only be liable to pay You against loss or damage by burglary, housebreaking, theft whilst the vehicle is laid up in garage and not in use.

Subject otherwise to the terms conditions limitations and exceptions of this Policy.

48. Liability and Fire and/or Theft (IMT 27)

Liability, Fire & Theft only:

It is hereby understood and agreed, notwithstanding anything to the contrary contained in the policy, that We shall not be liable under “Section 1 - Loss or damage to the vehicle - (OWN DAMAGE)” of the Policy, except in respect of loss or damage by fire, explosion, self-ignition, lightning, and/or burglary, housebreaking, theft, and/or riot, strike, malicious damage, terrorism and/or storm, tempest, flood, inundation and earthquake.

Liability & Fire only:

It is hereby understood and agreed, notwithstanding anything to the contrary contained in the policy, that We shall not be liable under “Section 1 - Loss or damage to the vehicle - (OWN DAMAGE)” of the Policy, except in respect of loss or damage by fire, explosion, self-ignition, lightning, and/or riot, strike, malicious damage, terrorism and/or storm, tempest, flood, inundation and earthquake.

Liability & Theft only:

It is hereby understood and agreed, notwithstanding anything to the contrary contained in the policy, that We shall not be liable under “Section 1 - Loss or damage to the vehicle - (OWN DAMAGE)” of the Policy, except in respect of loss or damage by burglary, housebreaking, theft.

Subject otherwise to the terms, conditions, limitations and exceptions of the Policy.

49. Legal Liability to Paid Driver and/or Conductor and/or Cleaner Employed in Connection with the Operation of Insured Vehicle (IMT 28)

In consideration of the payment of an additional premium, as specified in the Policy Schedule/Endorsement, and subject to the terms, conditions, limitations and exceptions of this Policy, it is hereby understood and agreed that notwithstanding anything to the contrary contained in this Policy, the insurer shall indemnify the insured against the insured's legal liability under the Employee's Compensation Act, 1923, the Fatal Accidents Act, 1855, or at Common Law, including subsequent amendments thereto prior to the date of this Endorsement, in respect of bodily injury or death of any paid driver and/or conductor and/or cleaner whilst engaged in the service of the insured in connection with the insured vehicle.

It is further understood and agreed that the insurer shall, in addition, be responsible for all costs and expenses incurred with its prior written consent.

The liability of the insurer under this Endorsement in respect of bodily injury or death shall be unlimited, subject always to the applicable laws.



Product UIN

IRDAN171RPMT0001V01202627

Provided always that

- a. This Endorsement shall not indemnify the insured in respect of any liability in cases where the insured holds or subsequently effects with any insurer or group of insurers a policy of insurance in respect of liability as herein defined for the insured's general employees.
- b. The insured shall take all reasonable precautions to prevent accidents and shall comply with all statutory obligations.
- c. The insured shall maintain records of the name of each paid driver, conductor, cleaner or person employed in loading and/or unloading, along with details of wages, salaries and other earnings paid to such employees, and shall allow the insurer to inspect such records at all times on demand.
- d. In the event of cancellation of the Policy at the request of the insured, no refund of premium paid in respect of this Endorsement shall be allowed.

Subject otherwise to the terms, conditions, limitations and exceptions of this Policy, except so far as necessary to meet the requirements of the Motor Vehicles Act, 1988.

50. Trailers (IMT 30)

In consideration of the payment of an additional premium, as specified in the Policy Schedule/Endorsement, and subject to the terms, conditions, limitations and exceptions of this Policy, it is hereby understood and agreed that the indemnity granted by this Policy shall extend to apply to the trailer attached to the insured vehicle, as specified in the Policy Schedule/Endorsement.

Provided always that

- a. The Insured Declared Value (IDV) of such trailer shall be limited up to the Sum Insured declared for the trailer as specified in the Policy Schedule/Endorsement.
- b. The term "trailer" shall not include its contents or anything contained thereon.
- c. Such indemnity shall not apply in respect of death or bodily injury to any person being conveyed by the said trailer otherwise than by reason of or in pursuance of a contract of employment.

Subject otherwise to the terms, conditions, limitations and exceptions of this Policy.

51. Reliability Trails and Rallies (IMT 31)

In consideration of the payment of an additional premium, it is hereby understood and agreed that, the indemnity granted by this Policy is extended to apply whilst the insured vehicle is engaged in the event specified in the Policy Schedule to be held at the location specified in the Policy Schedule on or about the date specified in the Policy Schedule under the auspices of as specified in the Policy Schedule provided that :-

- a. No indemnity shall be granted by this Endorsement to promoters of the event.
- b. This Policy does not cover use for organised racing, pace making or speed testing.
- c. During the course of the specified event, We shall not be liable in respect of death of or bodily injury to any person being carried in or upon or entering or getting on to or alighting from the insured vehicle at the time of the occurrence of the event out of which any claim arises.

It is further understood and agreed that while the insured vehicle is engaged in the specified event, You shall bear first, the amount specified in the Policy Schedule (or any less amount for which the claim may be assessed) of each and every claim under Section 1 of this Policy.

Provided that if We shall make any payment in exercise of its discretion under Section F.6.1.f of the policy in settlement of any claim and such payment includes the amount for which You are responsible by reason of this Endorsement, then You shall repay to Us forthwith the amount for which You are so responsible.

For the purpose of this Endorsement the expression "claim" shall mean a claim or series of claims arising out of one event.

Subject otherwise to the terms, conditions, limitations and exceptions of this Policy.

52. Accidents to Soldiers / Sailors / Airmen Employed as Drivers (IMT 32)

In consideration of the payment of an additional premium, as specified in the Policy Schedule/Endorsement, and subject to the terms, conditions, limitations and exceptions of this Policy, it is hereby understood and agreed that in the event of any Soldier, Sailor or Airman employed by you to drive the insured vehicle being injured or killed whilst so employed, the insurer shall indemnify the insured against the insured's liability to indemnify the Ministry of Defence under the applicable regulations.

It is further understood and agreed that the liability of the insurer under this Endorsement in respect of bodily injury or death shall be unlimited, subject to applicable laws and regulations.



Product UIN

IRDAN171RPMT0001V01202627

Subject otherwise to the terms, conditions, limitations and exceptions of this Policy.

D. Standalone Own Damage Policy (SAOD)

We can offer the policy on a standalone basis and the following Third Party Benefits will not be applicable: Liability To Third Parties, Personal Accident Cover For Owner-Driver, Personal Accident cover to You or any named person other than paid driver or cleaner (IMT 15), Personal Accident to Unnamed Passengers other than You and the Paid driver and Cleaner (IMT 16), Personal Accident Cover to Paid Drivers, Cleaners and Conductors (IMT 17), Reduction in the limit of Liability for Property damage (IMT 20), Legal Liability to paid driver and/or conductor and/or cleaner employed in connection with the operation of the insured vehicle For all Classes of vehicles.) (IMT 28), Accidents to Soldiers, Sailors, Airmen employed as drivers (IMT 32), Owner Driver Accident Cover Booster, Passenger Accident Cover Booster

Note: SAOD will only be applicable if a Motor Third Party Liability insurance is already in existence or is taken simultaneously

E. General Exclusions

These General Exclusions apply in addition to the specific conditions mentioned under each coverage/optional coverage of this Policy We will not be liable to cover and pay if:

1. Any accidental loss, damage, or liability that happens outside the geographical area listed in your Policy Schedule.
2. Any claims resulting from agreements or contracts you have signed (contractual liability).
3. Any accidental loss, damage, or liability that occurs while the insured vehicle is:
 - a. Being used in a way that violates the "Limitations as to Use" section; or
 - b. Being driven by any person not listed in the "Driver's Clause."
4. Any accidental loss or damage to any property whatsoever or any loss or expense whatsoever resulting or arising there from or any consequential loss.
5. We will not pay for loss of or damage to any externally fitted non-electrical accessories / fibre glass fuel tank unless same is opted by you by payment of additional premium) and recorded in the Policy Schedule

6. Any liability caused by ionisation, nuclear radiation, radioactivity, or nuclear waste.
7. Any accidental loss, damage, or liability caused by nuclear weapons.
8. Any accidental loss, damage, or liability caused by war, invasion, civil war, rebellion, or similar military actions. If you make a claim during such events, it is your responsibility to prove that the accident was completely unrelated to the conflict. In the absence of a valid proof, we are not liable to make any payment in respect of such a claim.

F. General Conditions

These General Conditions apply in addition to the specific conditions mentioned under each coverage/optional coverage/additional optional coverage of this Policy.

1. Hire Purchase Agreement (IMT 5)

In consideration of the insured vehicle being subject to a Hire Purchase Agreement, as specified in the Policy Schedule/Endorsement, and subject to the terms, exceptions, conditions and limitations of this Policy, it is hereby understood and agreed that the financier/owner as specified in the Policy Schedule/Endorsement (hereinafter referred to as the "Owners") are the owners of the insured vehicle, and that the insured vehicle is subject to a Hire Purchase Agreement made between the Owners and the insured.

It is further understood and agreed that the Owners shall be entitled to receive any monies which, but for this Endorsement, would be payable to the insured under this Policy in respect of loss of or damage to the insured vehicle which cannot be made good by repair and/or replacement of parts, and such monies shall be paid to the Owners so long as they remain the owners of the insured vehicle, and their receipt shall be a full and final discharge to the insurer in respect of such loss or damage.

It is further declared and agreed that for the purpose of the Personal Accident Cover for the owner-driver granted under this Policy, the insured named in the Policy shall continue to be deemed as the owner-driver, subject to compliance with the provisions of this Policy relating to such cover.

Save as expressly provided by this Endorsement, nothing herein shall modify or affect the rights and liabilities of the insured or the insurer respectively under or in connection with this Policy.

Subject otherwise to the terms, exceptions, conditions and limitations of this Policy.

2. Lease agreement (IMT 6)

It is hereby understood and agreed that that financial institution named in the Policy Schedule, are the Owners of the insured vehicle and that the insured vehicle is the subject of a Lease Agreement made between the Lessor on the one part and You on the other part and it is further understood and agreed that the Lessors are interested in any monies, which but for this Endorsement would be payable to You under this Policy in respect of such loss or damage to the insured vehicle as cannot be made good by repair and/or replacement of parts and such monies shall be paid to the Lessors as long as they are the owners of the insured vehicle and their receipt shall be a full and final discharge to Us in respect of such loss or damage.

It is also understood and agreed that notwithstanding any provision in the Leasing Agreement to the contrary, this Policy is issued to You as the principal party and not as agent or trustee and nothing herein contained shall be construed as constituting You an agent or trustee for the Lessors or as an assignment (whether legal or equitable) by You to the Lessors, of his rights benefits and claims under this Policy and further nothing herein shall be construed as creating or vesting any right in the Owner/Lessor to sue the insurer in any capacity whatsoever for any alleged breach of its obligations hereunder.

It is further declared and agreed that for the purpose of the Personal Accident Cover for the owner-driver granted under this Policy, You will continue to be deemed as the owner-driver subject to compliance of provisions of the Policy relating to this cover.

Save as by this Endorsement expressly agreed nothing herein shall modify or affect the rights and liabilities of You or the insurer respectively under or in connection with this Policy.

Subject otherwise to the terms exceptions conditions and limitations of this Policy.

3. Hypothecation Agreement (IMT 7)

In consideration of the insured vehicle being subject to a hypothecation/pledge arrangement, as specified in the Policy Schedule/Endorsement, and subject to the terms, exceptions, conditions and limitations of this Policy, it is hereby understood and agreed that the insured vehicle is pledged to/hypothecated with the entity specified in the Policy Schedule/Endorsement (hereinafter referred to as the "Pledgee").

Product UIN

IRDAN171RPMT0001V01202627

It is further understood and agreed that the Pledgee shall be entitled to receive any monies which, but for this Endorsement, would be payable to the insured under this Policy in respect of loss of or damage to the insured vehicle which cannot be made good by repair and/or replacement of parts, and such monies shall be paid to the Pledgee so long as they remain the Pledgee of the insured vehicle, and their receipt shall be a full and final discharge to the insurer in respect of such loss or damage.

It is further declared and agreed that for the purpose of the Personal Accident Cover for the owner-driver granted under this Policy, the insured named in the Policy shall continue to be deemed as the owner-driver, subject to compliance with the provisions of this Policy relating to such cover.

Save as expressly provided by this Endorsement, nothing herein shall modify or affect the rights or liabilities of the insured or the insurer respectively under or in connection with this Policy or any term, provision or condition thereof.

Subject otherwise to the terms, exceptions, conditions and limitations of this Policy.

4. Compulsory Deductible (IMT 22)

It is hereby understood and agreed despite anything contained elsewhere in this policy, that You shall bear under Section 1 of the policy in respect of each and every event (including event giving rise to a total loss/constructive total loss) the amount specified in the Policy Schedule (or any less expenditure which may be incurred) of any expenditure for which provision has been made under this policy and/or of any expenditure by the insurer in the exercise of his discretion under Section F.6.1.f of this policy .

If the expenditure incurred by Us shall include any amount for which You are responsible, then such amount shall be repaid by You to us forthwith.

For the purpose of this Endorsement the expression "event" shall mean an event or series of events arising out of one cause in connection with the insured vehicle in respect of which indemnity is provided under this policy.

Subject otherwise to the terms conditions limitations and exceptions of this Policy.

5. Conditions precedent to contract

1. The premium for the selected Period of Insurance must be paid before the Policy start date, as chosen by you in the proposal form.
2. The Company's liability to make any payment under this Policy is subject to the below, and failure to meet these requirements may result in denial of claims.
 - a. The insured complying with all terms, conditions, and endorsements of this Policy; and
 - b. The accuracy and completeness of all statements and information provided in the proposal form.

6. Conditions during the contract

1. Duties and Obligations after Occurrence of an Insured event
 - a. The insured must inform the Company in writing immediately after any accidental loss or damage. In the event of a claim, the insured must provide all required information and assistance for claim processing. Any letters, notices, summons, or legal documents received must be shared with the Company immediately.
 - b. The insured must also inform the Company in writing as soon as they become aware of any prosecution, inquest, or fatal inquiry related to an incident that may lead to a claim under this Policy.
 - c. In case of theft or any criminal act, the insured must immediately inform the police and cooperate with the Company in all actions required to investigate and pursue the matter.
 - d. The insured must not admit liability, make any offer or promise, or settle any claim without prior written consent from the Company. The Company has the right to take over and manage the defence, settlement, or legal proceedings in the name of the insured. The insured must provide full cooperation as required.
 - e. At any stage after an event leading to a claim under Section 1, the Company may choose to pay the full amount of its liability under that section and discontinue handling any defence, settlement, or legal proceedings thereafter.
 - f. The Company may, at its discretion repair, restore, or replace the insured vehicle or its parts/accessories; or settle the claim in cash.

- i. The Company's liability shall not exceed:
1. In case of total loss / constructive total loss – the Insured's Declared Value (IDV) (including accessories thereon) less the wreck value.
 2. In case of partial loss – the actual and reasonable cost of repairs or replacement, subject to applicable depreciation limits.
 3. Salvage, if any, will be taken over by us. The Company shall not deduct any amount in lieu of salvage value.

7. Reasonable Care

The Insured shall take all reasonable steps to protect the insured vehicle from loss or damage and ensure it is properly maintained in efficient condition.

8. Right to Inspect

The Company shall have the right to inspect the insured vehicle, its parts, and related records at any time. In case of an accident or breakdown, the vehicle should not be left unattended without proper precautions. Any additional damage caused due to use of the vehicle before necessary repairs will be at the insured's own risk.

9. Cancellation

I. Cancellation by Insurer

The Company may cancel the Policy on grounds of proven fraud, misrepresentation, non-disclosure of material facts, and non-co-operation by the insured/their representatives by giving a minimum of 7 days' notice. Section 2 - Liability to Third Parties" of the Policy will also be cancelled from inception if a fraudulent act is committed at the time of insuring the vehicle, involving misrepresentation, misdescription or non-disclosure by You or anyone acting on Your behalf with an intent to deceive Us or to induce Us to issue an insurance policy. In such cases, the Policy may be treated as void from inception, and no premium or claims may be payable.

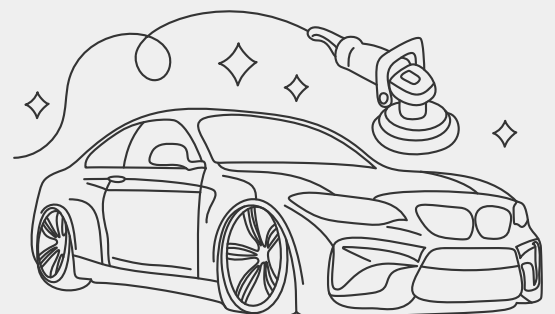

In the event of Theft, Total Loss (TL), Constructive Total Loss (CTL), or Cash-loss, We will cancel "Section 1: Loss or damage to the vehicle (Own Damage)" of the Policy effective from the date of loss. Additionally, We will cancel "Section 2: Liability to Third Parties" of the Policy, provided You cancel the road registration of the wreck or obtain a statutory Motor Third Party liability insurance policy covering the wreck from the date of loss and submit the original documentary evidence to Us. We will refund the premium only for those Policy years where the risk coverage has not yet commenced.

II. Cancellation & Refund by Insured

- a. The insured may cancel the policy anytime without assigning any reason.
- b. We will refund proportionate premium for unexpired policy period, if the term of the policy is up to 1 year and there is no claim(s) made in the policy period, subject to submission of proof that the vehicle is insured elsewhere at least for Liability Only cover.
- c. We will refund premium for the unexpired policy period, in respect of policy with the term more than 1 year and the risk coverage for such policy years has not commenced, subject to submission of proof that the vehicle is insured elsewhere at least for Liability Only cover.
- d. If the "Own Damage Cover" under your policy is cancelled during the policy period, then your policy shall be governed by the standard terms and conditions of "Act Only" policy for the Third Party cover during the remaining period of the policy.
- e. Statutory Motor Third Party Liability insurance or any other compulsory insurance mandated by law can NOT be cancelled, except in case of double insurance or total loss. In such cases a policy can be cancelled only after ensuring that the vehicle is insured elsewhere, at least for Liability Only cover and after surrender of the original Certificate of Insurance for cancellation.
- f. If the insured vehicle is covered under more than one policy with identical coverage (Double Insurance), then the policy commencing later may be cancelled by you subject to the following:

Earlier dated policy can be cancelled only due to written intimation to the insurer by the Banks/ Financial Institutions.

10. Contribution

If at the time of occurrence of an event that gives rise to any claim under this policy, there is in existence any other insurance covering the same loss, damage or liability, the Company shall not be liable to pay or contribute more than its ratable proportion of any compensation cost or expense.

11. Transfer of Insurance

- a. Liability Only cover will automatically transfer to the new owner (deemed to be insured) from the date of transfer.
- b. The new owner shall apply (along with evidence of sale and original certificate of insurance) within 14 days from the date of transfer for updating records and issuance of a fresh Certificate of Insurance/endorsement. The new owner will then be deemed the insured, and their details will form the basis of the contract.
- c. Post 14 days window, the transfer will be considered from the date the request is received and upon payment of differential premium (if any).
- d. The previous owner's No Claim Bonus (NCB) does not transfer to the new owner for their benefit.
- e. In case the new owner is entitled to a lesser or no NCB/Super NCB, recovery of the differential premium shall be made before effecting the transfer.

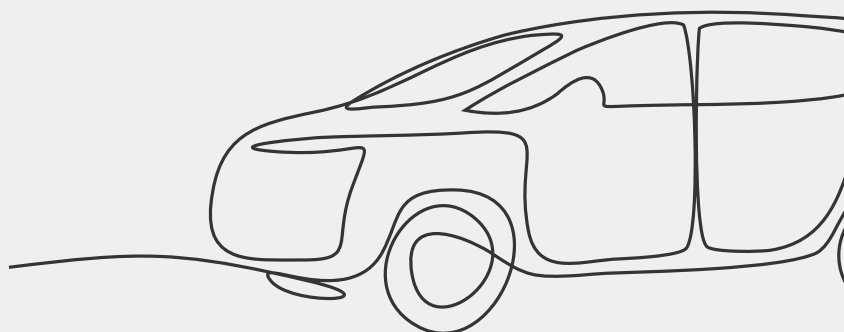

12. No Claim Bonus (NCB)

Only in case of No claim made or pending during the preceding year(s) of insurance, the insured is rewarded with a discount on the Own Damage (OD) section premium of the policy.

NCB Discount Grid:

No claim during the preceding consecutive year(s)	Discount %
1 year	20%
2 years	25%
3 years	35%
4 years	45%
5 years	50%

In case of existing eligibility for 55% or 65% NCB under the old tariff, that higher NCB will continue in future renewals until a claim occurs.

Conditions:

1. Accumulation and Transfer of NCB is applicable if the vehicle was **continuously insured for at least 12 months** and the policy **renewed within 90 days** of expiry date, except in the below cases:
 - i. Vehicles sold the NCB can be carried forward to the new policy up to 3 years from the expiry of the previous policy. Here the NCB will be the rate earned at the end of the last 12-month policy.
 - ii. NCB earned abroad: You can apply your overseas No Claim Bonus to this policy. The NCB will be granted as per entitlement, if you haven't made a claim in recent years. To be eligible, you must buy this policy within three years of your foreign policy ending.

Product UIN

IRDAN171RPMT0001V01202627

2. Transfer of No Claim Bonus

NCB belongs to the original insured and not linked to the vehicle or policy. Which means for transfer of policy, the NCB will depend upon the new owner's eligibility except in the below cases:

- a. Legal heirs (spouse, children, parents) take custody of the vehicle upon the insured's death.
- b. Employees take custody of the institution-owned vehicle used exclusively by them, subject to employer confirmation for exclusive operation during the period in which the NCB was earned.

3. NCB is applicable on premium under "Section 1: Own Damage", including discounts and loadings as per erstwhile IMT.

4. NCB will not be affected in case:

- a. Claim under optional benefits where condition of claim admissibility under "Section 1: Own Damage" of the Policy is not required.
- b. Damage to only windshield glass of the parked insured vehicle by external objects.
- c. Loss due to flood/earthquake/act of god perils to the insured parked vehicle.

13. Claims:

Intimation:

The insured / claimant will intimate claim to Us via:

Toll Free Number – 1800-268-4444

Email -claims@kiwiinsurance.com

Website – www.kiwiinsurance.com

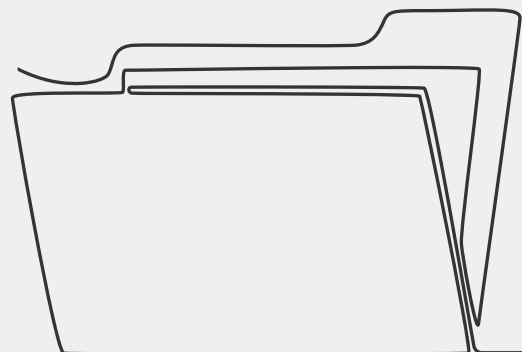



Product UIN

IRDAN171RPMT0001V01202627

- Notice of claim must be given immediately after an actual or potential loss occurs, or as soon as reasonably possible.
- In case of theft, the insured must inform both the Police and the insurer within 48 hours and obtain an FIR or written acknowledgement from the Police.
- Keep the following details ready when contacting the call centre:
 1. Your Contact Numbers
 2. Policy Number
 3. Name of Insured
 4. Date & Time of loss
 5. Location of loss
 6. Nature of Loss
 7. Place & Contact Details of the person at the loss location

Note: You may be asked for additional documents. For more details, please refer to the intimation cum preliminary claim form.

Other:

1. In the event the claim is not settled within timelines prescribed by IRDAI, the Company shall be liable to pay interest at a rate, which is 2% above the bank rate from the date of receipt of intimation till the date of actual payment.
2. Failure to furnish evidence within the time required shall not invalidate nor reduce any claim if, You can satisfy Us that it was not reasonably possible for You to give the proof within such time.
3. In case of Total Loss and/or Theft claim, applicable subsidy amount availed as per government policy will be reduced from IDV for claim settlement.

14. Special Conditions

In the event of the death of the sole insured, this policy will not immediately lapse but will remain valid for a period of three months from the date of the death of insured or until the expiry of this policy (whichever is earlier). During this period, legal heir(s) of the insured to whom the custody and use of the Motor Vehicle passes may apply to have this policy transferred to them or obtain a new insurance policy for the Motor Vehicle.

All such applications should be accompanied by:

1. Death certificate in respect of the insured
2. Proof of title to the vehicle
3. Original Policy

15. Redressal of Grievance

We are committed to extend the best possible services to our policyholders. However, if you are not satisfied with our services and wish to lodge a complaint, please feel free to call our **24X7 Toll free** number **1800-268-4444** or you may email us at **customer.care@kiwiinsurance.com**

If You are not satisfied with our resolution from above, then You may escalate the matter to the grievance officer at GRO@kiwiinsurance.com

For updated details of grievance officer, kindly refer the link:

<https://www.kiwiinsurance.com/grievance-redressal/>

Grievance may also be lodged at IRDAI Integrated Grievance Management System- **www.igms.irda.gov.in**

If you do not get a satisfactory response from us and you wish to pursue other avenues for redressal of grievances, you may approach the Insurance Ombudsman appointed by IRDAI under the Insurance Ombudsman Scheme.

The contact details of the Insurance Ombudsman centers are mentioned in **Annexure 1**.

Annexure 1

List of Insurance Ombudsmen

S.No	Address	Jurisdiction
1.	Dr. Pranai Prabhakar Office of the Insurance Ombudsman, Jeevan Prakash Building, 6th floor, Tilak Marg, Relief Road, AHMEDABAD – 380 001. Tel.: 079 - 25501201/02 Email: oio.ahmedabad@cioins.co.in	Gujarat, Dadra & Nagar Haveli, Daman and Diu.
2.	Ms Neerja Kapur Office of the Insurance Ombudsman, Jeevan Soudha Building,PID No. 57-27-N-19 Ground Floor, 19/19, 24th Main Road, JP Nagar, 1st Phase, Bengaluru – 560 078. Tel.: 080 - 26652048 / 26652049 Email: oio.bengaluru@cioins.co.in	Karnataka
3.	Shri Ajay Kumar Office of the Insurance Ombudsman, 1st floor,"Jeevan Shikha", 60-B,Hoshangabad Road, Opp. Gayatri Mandir,Arera Hills Bhopal – 462 011. Tel.: 0755 - 2769201 / 2769202 / 2769203 Email: oio.bhopal@cioins.co.in	Madhya Pradesh, Chhattisgarh
4.	Shri Rashmi Raman Singh Office of the Insurance Ombudsman, 62, Forest park, Bhubaneswar – 751 009. Tel.: 0674 - 2596461 /2596455/2596429/2596003 Email: oio.bhubaneswar@cioins.co.in	Odisha
5.	Ms Alka Jha Office Of The Insurance Ombudsman, Jeevan Deep Building SCO 20-27, Ground Floor Sector- 17 A, Chandigarh – 160 017. Tel.: 0172-2706468 Email: oio.chandigarh@cioins.co.in	Punjab, Haryana (excluding Gurugram, Faridabad, Sonapat and Bahadurgarh), Himachal Pradesh, Union Territories of Jammu & Kashmir,Ladakh & Chandigarh

S.No	Address	Jurisdiction
6.	Shri K.Vinayak Rao Office of the Insurance Ombudsman, Fatima Akhtar Court, 4th Floor, 453, Anna Salai, Teynampet, CHENNAI – 600 018. Tel.: 044 - 24333668 / 24333678 Email: oio.chennai@cioins.co.in	Tamil Nadu, PuducherryTown and Karaikal (which are part of Puducherry)
7.	Shri Mukhmeet Singh Bhatia Office of the Insurance Ombudsman, 2/2 A, Universal Insurance Building, Asaf Ali Road, New Delhi – 110 002. Tel.: 011 - 46013992/23213504/23232481 Email: oio.delhi@cioins.co.in	Delhi & following Districts of Haryana - Gurugram, Faridabad, Sonepat & Bahadurgarh
8.	Shri Ajay Kumar Sharma Office of the Insurance Ombudsman, Jeevan Nivesh, 5th Floor, Near Pan Bazar , S.S. Road, Guwahati – 781001(ASSAM). Tel.: 0361 - 2632204 / 2602205 / 2631307 Email: oio.guwahati@cioins.co.in	Assam, Meghalaya, Manipur, Mizoram, Arunachal Pradesh, Nagaland and Tripura
9.	Ms G Shobha Reddy Office of the Insurance Ombudsman, 6-2-46, 1st floor, "Moin Court", Lane Opp.Hyundai Showroom , A. C. Guards, Lakdi-Ka-Pool, Hyderabad - 500 004. Tel.: 040 - 23312122 / 23376991 / 23376599 / 23328709 / 23325325 Email: oio.hyderabad@cioins.co.in	Andhra Pradesh, Telangana, Yanam and part of Union Territory of Puducherry
10.	Shri Satyajeet Rajan Office of the Insurance Ombudsman, Jeevan Nidhi – II Bldg., Gr. Floor, Bhawani Singh Marg, Jaipur - 302 005. Tel.: 0141- 2740363 Email: oio.jaipur@cioins.co.in	Rajasthan

S.No	Address	Jurisdiction
11.	<p>Shri Pradeep Kumar Jain</p> <p>Office of the Insurance Ombudsman, 10th Floor, Jeevan Prakash, LIC Building, Opp to Maharaja's College Ground, M.G. Road, Kochi - 682 011. Tel.: 0484 - 2358759 Email: oio.ernakulam@cioins.co.in</p>	Kerala, Lakshadweep, Mahe-a part of Union Territory of Puducherry
12.	<p>Ms. Manju Bagga</p> <p>Office of the Insurance Ombudsman, Hindustan Bldg. Annexe, 7th Floor, 4, C.R. Avenue, KOLKATA - 700 072. Tel.: 033 - 22124339 / 22124341 Email: oio.kolkata@cioins.co.in</p>	West Bengal, Sikkim, Andaman & Nicobar Islands
13.	<p>Shri Sanjai Singh</p> <p>Office of the Insurance Ombudsman, 6th Floor, Jeevan Bhawan, Phase-II, Nawal Kishore Road, Hazratganj, Lucknow - 226 001. Tel.: 0522 - 4002082 / 3500613 Email: oio.lucknow@cioins.co.in</p>	Districts of Uttar Pradesh : Lalitpur, Jhansi, Mahoba, Hamirpur, Banda, Chitrakoot, Allahabad, Mirzapur, Sonbhadra, Fatehpur, Pratapgarh, Jaunpur, Varanasi, Gazipur, Jalaun, Kanpur, Lucknow, Unnao, Sitapur, Lakhimpur, Bahraich, Barabanki, Raebareli, Sravasti, Gonda, Faizabad, Amethi, Kaushambi, Balrampur, Basti, Ambedkarnagar, Sultanpur, Maharajgang, Santkabirnagar, Azamgarh, Kushinagar, Gorkhpur, Deoria, Mau, Ghazipur, Chandauli, Ballia, Sidharathnagar
14.	<p>Ms Sarojini S Dikhale</p> <p>Office of the Insurance Ombudsman, 3rd Floor, Jeevan Seva Annexe, S. V. Road, Santacruz (W), Mumbai - 400 054. Tel.: 022 - 69038800/27/29/31/32/33 Email: oio.mumbai@cioins.co.in</p>	Metropolitan Region excluding wards in Mumbai - i.e M/E, M/W, N , S and T covered under Office of Insurance Ombudsman Thane and excluding areas of Navi Mumbai

S.No	Address	Jurisdiction
15.	Shri Rajiv Talwar Office of the Insurance Ombudsman, Bhagwan Sahai Palace 4th Floor, Main Road, Naya Bans, Sector 15, Distt: Gautam Buddh Nagar, U.P-201301. Tel.: 0120-4027589 Email: oio.noida@cioins.co.in	State of Uttarakhand and the following Districts of Uttar Pradesh: Agra, Aligarh, Bagpat, Bareilly, Bijnor, Budaun, Bulandshehar, Etah, Kannauj, Mainpuri, Mathura, Meerut, Moradabad, Muzaffarnagar, Oraiyya, Pilibhit, Etawah, Farrukhabad, Firozbad, Gautam Buddh nagar, Ghaziabad, Hardoi, Shahjahanpur, Hapur, Shamli, Rampur, Kashganj, Sambhal, Amroha, Hathras, Kanshiramnagar, Saharanpur
16.	Shri Inderjeet Singh Office of the Insurance Ombudsman, 2nd Floor, Lalit Bhawan, Bailey Road, Patna 800 001. Tel.: 0612-2547068 Email: oio.patna@cioins.co.in	Bihar, Jharkhand
17.	Ms. Rachna Khare Office of the Insurance Ombudsman, Jeevan Darshan Bldg., 3rd Floor, C.T.S. No.s. 195 to 198, N.C. Kelkar Road, Narayan Peth, Pune – 411 030. Tel.: 020-24471175 Email: oio.pune@cioins.co.in	State of Goa and State of Maharashtra excluding areas of Navi Mumbai, Thane district, Palghar District, Raigad district & Mumbai Metropolitan Region
18.	Shri Umesh Sinha Office of the Insurance Ombudsman, Jeevan Chintamani Building, 2nd Floor, Near New RTO Office, Louis Wadi, Vasantrya Naik Mahamarg, Thane (West)- 400604 Tel.: 022-20812868/69 Email: oio.thane@cioins.co.in	Area of Navi Mumbai, Thane District, Raigad District, Palghar District and wards of Mumbai, M/ East, M/West, N, S and T.